



**BATHROOM CATALOG N° /02**



[www.birex.it](http://www.birex.it)



**N° /02**  
**BATHROOM CATALOG**





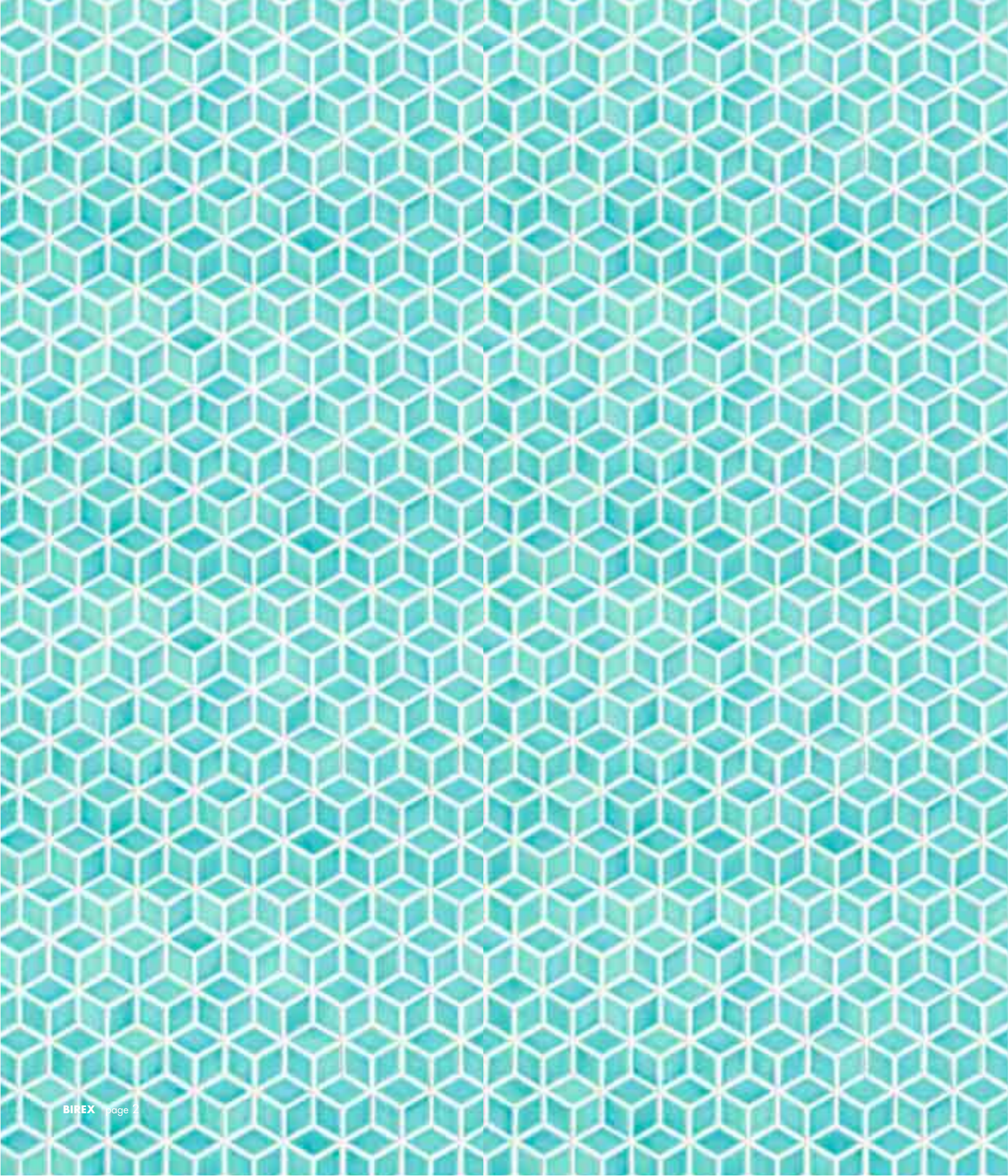

N° /02

## IL BAGNO

**IL BAGNO E' UN LUOGO SPECIALE, PERCHE' E' IL POSTO DOVE CI SI PRENDE CURA DI SE, MA NON SOLO. SI POSSONO ANCHE SVOLGERE TUTTE QUELLE ATTIVITA' CHE AIUTANO A GESTIRE I NOSTRI INDUMENTI, LA CASA, A SVOLGERE QUELLE FUNZIONI DI CONTENERE, LAVARE... E' PER QUESTO CHE DEVE ESSERE FUNZIONALE, ORDINATO E PIACEVOLE.**

### **\_EN THE BATHROOM**

The bathroom is a special place where we dedicate time to personal care, and much more. Here, we can also carry out all those activities that help us organise our clothes and our home, also storing and doing the laundry... this is why it needs to be functional, tidy and attractive.

### **\_DE DAS BAD**

Das Bad ist ein ganz besonderer Ort, an dem wir uns der Schönheit und der Körperpflege widmen. Es können hier aber auch viele andere Tätigkeiten rund um Wäsche und Haushalt durchgeführt werden, wie z. B. aufbewahren, waschen, trocknen... und aus diesem Grund sollte der Raum funktionell, ordentlich und freundlich sein.

### **\_FR LA SALLE DE BAINS**

La salle de bains est une pièce spéciale parce que c'est là où l'on prend soin de soi, mais ce n'est pas tout. On peut également y effectuer d'autres activités utiles à l'entretien de la maison, comme laver, ranger, s'occuper du linge. Voilà pourquoi cette pièce doit être fonctionnelle, bien organisée et agréable.

### **\_ES EL BAÑO**

El baño es un lugar especial, porque ahí es donde uno se asea y mucho más, porque también se pueden llevar a cabo las tareas relativas al vestuario, a la casa, además de almacenar, lavar... por esto debe ser funcional, ordenado y placentero.



## Lavare

Doing the laundry  
Waschen  
Laver  
Lavar

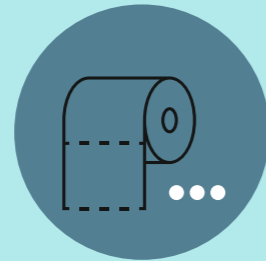

## Riporre

Organising  
Ordnen  
Ranger  
Guardar



## Lavarsi

Washing  
Sich waschen  
Se laver  
Asearse



## Contenere

Storing  
Verstauen  
Contenir  
Almacenar



## Asciugare

Drying  
Trocknen  
Sécher  
Secar

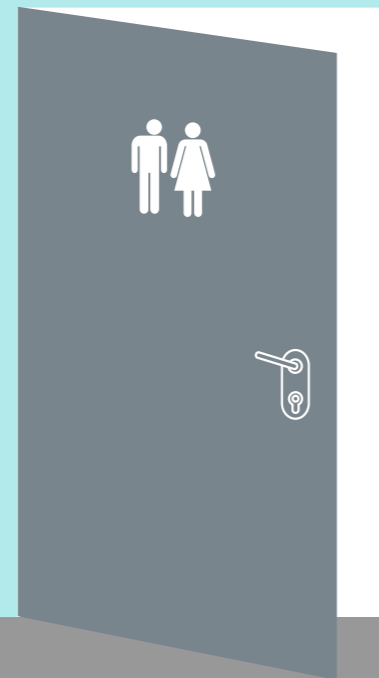

**Il bagno,  
uno spazio  
che raccoglie  
diverse  
funzioni.**



**\_EN** The bathroom is a space that hosts different functions.

**\_DE** Das Bad, ein Ort, der verschiedene Funktionen vereint.

**\_FR** La salle de bains, un espace pour différentes fonctions.

**\_ES** El baño, un espacio que reúne varias funciones.



# La qualità BIREX, punto per punto

**\_EN** BIREX quality, explained point by point.

**\_DE** Die Qualität von BIREX, Punkt für Punkt.

**\_FR** La qualité BIREX, point par point.

**\_ES** La calidad BIREX, paso a paso.

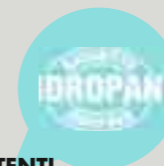

**I MOBILI BIREX SONO RESISTENTI ALL'ACQUA E ALL'UMIDITA'.**

**BIREX FURNITURE IS WATER AND MOISTURE-RESISTANT.**

**DIE MÖBEL VON BIREX SIND GEGEN WASSER UND FEUCHTIGKEIT IMMUN.**

**LES MEUBLES BIREX SONT RÉSISTANTS À L'EAU ET À L'HUMIDITÉ.**

**LOS MUEBLES BIREX RESISTEN AL AGUA Y A LA HUMEDAD.**



**LA FINITURA SAND ANTIGRAFFIO E' REALIZZATA CON LACCATURA ALL'ACQUA.**

**THE SCRATCH-RESISTANT SAND FINISH IS MADE OF WATER BASED ACRYLICS.**

**DAS KRATZFESTE FINISH WIRD DURCH LACKIERUNGEN AUF WASSERBASIS ERZIELT.**

**LA FINITION "SAND" ANTI-RAYURE EST RÉALISÉE AVEC UNE LAQUE À L'EAU.**

**EL ACABADO RESISTENTE AL RAYADO HA SIDO REALIZADO CON LACADO AL AGUA.**

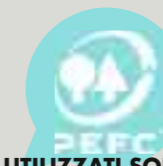

**I PANNELLI UTILIZZATI SONO ECOLOGICI PERCHE' REALIZZATI CON LEGNO RICICLATO.**

**THE PANELS WE USE ARE ENVIRONMENT FRIENDLY; DERIVING FROM RECYCLED WOOD.**

**DIE VERWENDETEN PLATTEN SIND UMWELTFREUNDLICH, DA SIE AUS RECYCELTEM HOLZ HERGESTELLT WERDEN.**

**LES PANNEAUX UTILISÉS SONT ÉCOLOGIQUES CAR ILS SONT EN BOIS RECYCLÉ.**

**LOS PANELES UTILIZADOS SON ECOLÓGICOS PORQUE REALIZADOS CON MADERA RECICLADA.**



**TUTTA LA FILIERA PRODUTTIVA É AL 100% ITALIANA.**

**THE ENTIRE PRODUCTION CHAIN OF PRODUCTION IS 100% ITALIAN.**

**DIE GESAMTE PRODUKTIONSKETTE IST ZU 100% ITALIENISCH**

**TOUTE LA FILIÈRE DE PRODUCTION EST 100% ITALIENNE.**

**TODA LA HILERA PRODUCTIVA ES ITALIANA AL 100%**

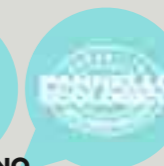

**DURATA E RESISTENZA SONO CERTIFICATE DAI RIGOROSI TEST CATAS.**

**CERTIFIED DURABILTY AND RESILIENCE VIA RIGOROUS CATAS LAB TESTING.**

**LEBENSDAUER UND HALTBARKEIT WERDEN ANHAND DER STRENGEN CATAS-TESTS ZERTIFIZIERT.**

**LA DURÉE ET LA RÉSISTANCE SONT CERTIFIÉES PAR DES TESTS CATAS RIGOUREUX.**

**DURACIÓN Y RESISTENCIA CERTIFICADAS POR LAS RIGUROSAS PRUEBAS CATAS.**



**MASSIMA EFFICIENZA NEI SERVIZI COMMERCIALI E DI ASSISTENZA TECNICA.**

**MAXIMUM EFFICIENCY IN COMMERCIAL SERVICES AND TECHNICAL ASSISTANCE.**

**MAXIMALE EFFIZIENZ DES VERTRIEBS UND DES TECHNISCHEN KUNDENDIENSTS.**

**EFFICACITÉ MAXIMALE DES SERVICES COMMERCIAUX ET DE L'ASSISTANCE TECHNIQUE.**

**MÁXIMA EFICIENCIA DE LOS SERVICIOS COMERCIALES Y DE ASISTENCIA TÉCNICA.**



**Trova  
le soluzioni  
bagno  
che fanno  
per te.**

**\_EN** Find bathrooms solutions to suit you.

**\_DE** Finden Sie die für Sie geeigneten Badlösungen.

**\_FR** Trouvez les meilleures solutions pour votre salle de bains.

**\_ES** Encuentra el baño justo para ti.



## HAI POCO SPAZIO E VUOI CONTENERE TUTTO IN UN PICCOLO BAGNO?

IN QUESTE PAGINE TROVERAI SOLUZIONI PER ORGANIZZARE E CONTENERE SOPRA IL WATER E IL BIDET E SOTTO IL LAVANDINO

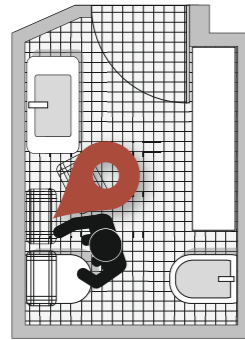

ACQUA e SAPONE

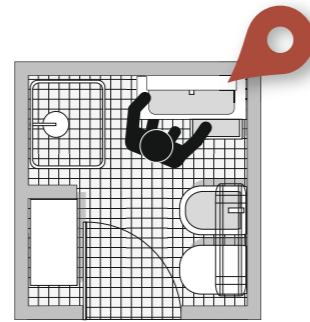

ACQUA e SAPONE

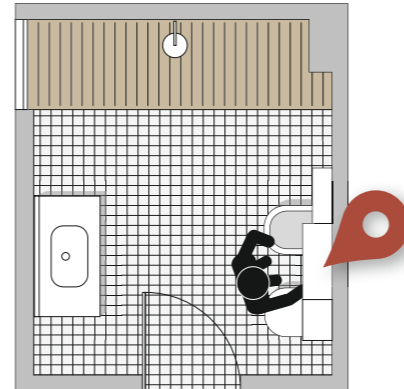

LAPIS

page 21/27/33/55/67/118/138

page 27

page 33

page 55

**\_EN** Do you have little space and want to store everything in a small bathroom? On these pages, you will find solutions for organising and storing above the toilet, bidet or under the sink.

**\_DE** Sie haben wenig Platz und möchten trotzdem alles in einem kleinen Bad unterbringen? Auf diesen Seiten finden Sie Lösungen, um den Stauraum über WC und Bidet und unter dem Waschbecken zu organisieren.

**\_FR** Vous avez peu de place et vous souhaitez tout ranger dans une petite salle de bains? Vous trouverez dans les pages suivantes des solutions pour organiser et pour ranger au-dessus du WC et du bidet et sous la vasque.

**\_ES** el espacio es reducido y quieres tenerlo todo en un baño pequeño? En estas páginas encontrarás soluciones para organizar y almacenar sobre el inodoro y el bidé y debajo del lavabo.

## VUOI ORGANIZZARE UN BAGNO/LAVANDERIA?

IN QUESTE PAGINE TROVERAI SOLUZIONI CHE TI PERMETTONO DI ORGANIZZARE IL BAGNO, CON LA LAVATRICE, L'ASCIUGATRICE, PORTA BIANCHERIA ANCHE CON LA POSSIBILITÀ DI ANTE RIENTRANTI

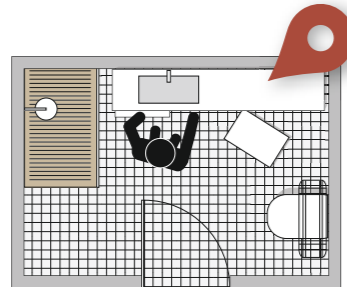

ACQUA e SAPONE

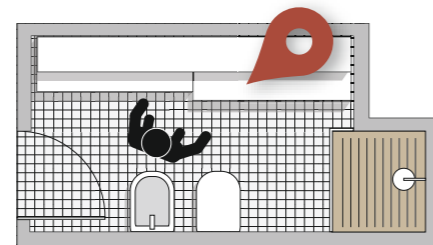

45

page 37/45/67/99/131

page 45

page 99

**\_EN** Do you want to organise a bathroom/laundry room? On these pages, you will find solutions that will allow you to organise a bathroom to include a washing machine, a tumble dryer and a laundry hanging rack, with the option of retracting doors.

**\_DE** Möchten Sie ein Badezimmer / eine Waschküche organisieren? Auf diesen Seiten finden Sie Lösungen, um das Bad mit Waschmaschine, Wäschetrockner und Wäscheablage.

**\_FR** Vous souhaitez une salle de bains / buanderie ? Vous trouverez dans les pages suivantes des solutions qui vous permettront d'organiser votre salle de bains avec un lave-linge, un sèche-linge, un panier à linge avec possibilité également de portes rentrantes.

**\_ES** Quieres organizar un baño/una lavandería? en estas páginas encontrarás las soluciones que te permiten organizar el baño, con lavadora, secadora, cesto para la ropa también con la posibilidad de incorporar puertas escamoteables.

## VUOI CHE IL TUO SPECCHIO ABBAIA MOLTE FUNZIONI?

SOLUZIONI PER SPECCHIO STENDINO, SPECCHIO CONTENITORE O SPECCHIO CON MENSOLA

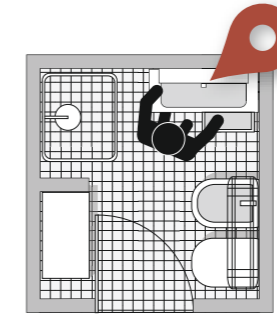

ACQUA e SAPONE

page 39/43/81/85/97/127

page 39

**\_EN** Do you want your mirror to have many functions? Solutions that offer a mirror unit/ laundry hanging rack, a mirror storage unit or a mirror with a shelf.

**\_DE** Möchten Sie einen Spiegel mit vielen Funktionen? Lösungen für Spiegel mit Wäscheständer, Spiegelschrank oder Spiegel mit Ablage.

**\_FR** Vous souhaitez un miroir multifonctionnel ? Solutions pour armoire de toilette avec étendoir à linge, armoire de toilette simple ou miroir avec étagère.

**\_ES** quieres que tu espejo tenga más funciones? soluciones para espejo con tendedero, armario con espejo o espejo con repisa.

## NECESSITI DI UNA PARETE ATTREZZATA?

SE HAI UNA PARETE VUOTA DA ATTREZZARE O SE HAI BISOGNO DI SPAZIO PER I TUOI SAPONI

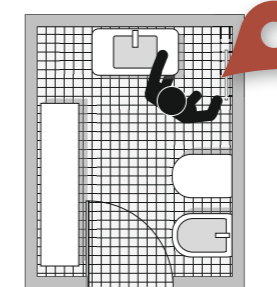

ACQUA e SAPONE

page 21/25/41

page 21

**\_EN** Do you need an accessorised wall system? Perhaps you have an empty wall to accessorise or you need space for your soaps.

**\_DE** Benötigen Sie eine ausgestattete Wand? Wenn Sie eine leere Wand nutzen möchten oder wenn Sie Platz für Ihre Seifen brauchen.

**\_FR** Vous avez besoin d'aménager une paroi ? Si vous avez une paroi vide à aménager ou si vous avez besoin de place pour vos produits de lavage.

**\_ES** necesitas una pared equipada? si tienes una pared vacía que equipar o si te hace falta espacio para tus jabones.

## CERCHI UNA PANCA O UN'ALZATA CHE AIUTI I BIMBI?

HAI UN BIMBO CHE  
VUOLE LAVARSI I  
DENTI DA SOLO?  
HAI BISOGNO DI  
UNA PANCA PER  
ALLACCIARTI LE  
SCARPE?



ACQUA e SAPONE

page 35/41/64/102

**\_EN** Are you looking for a bench or a step element for children?  
Do you have a child who wants to brush his/her own teeth? Do you need a bench where you can tie your shoelaces?

**\_DE** Suchen Sie eine Bank oder eine Erhöhung, die Ihren Kindern hilft? Haben Sie ein Kind, das sich alleine die Zähne putzen möchte? Brauchen Sie eine Bank, um sich die Schuhe zuzubinden?

**\_FR** Vous cherchez un banc ou un rehausseur pour aider vos enfants ? Vous avez un enfant qui veut se laver les dents tout seul ? Vous avez besoin d'un banc pour lacer vos.

**\_ES** Estás buscando un banco o una banqueta h 260 cm que ayude a tus niños? tu niño quiere lavarse los dientes él sólo? ¿necesitas un banco para atarte los zapatos?

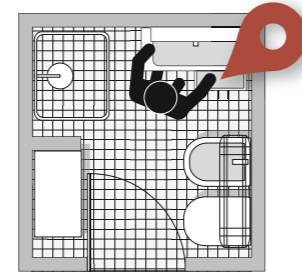

ACQUA e SAPONE

page 35

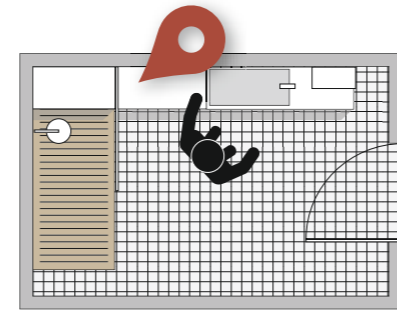

45

page 102

## VUOI UN CONTENITORE ATTREZZATO PER I TRUCCHI?

UNA COLONNA  
ATTREZZATA CHE  
CONTIENE SPECCHI,  
LUCE E TRUCCHI

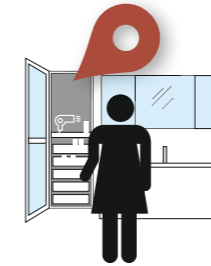

CAMPUS

page 161

**\_EN** Do you want an accessorised storage unit for your makeup?  
An accessorised pillar that contains mirrors, a light and makeup.

**\_DE** Möchten Sie einen Schrank mit Innenausstattung für Ihre Schminkutensilien?  
Ein mit Spiegeln und Beleuchtung ausgestatteter Schrank, der viel Platz für Schminkutensilien bietet.

**\_FR** Vous souhaitez un meuble aménagé pour votre maquillage ? Une colonne aménagée avec miroir, éclairage et rangement pour le maquillage.

**\_ES** Quieres un contenedor equipado para los productos de maquillaje? una columna equipada que contiene espejos, luz y productos para el maquillaje.

## HAI SPAZI RISTRETTI?

QUESTE SOLUZIONI TI  
DANNO LA POSSIBILITÀ  
DI AVERE UN PIANO A  
PROFONDITÀ RIDOTTA

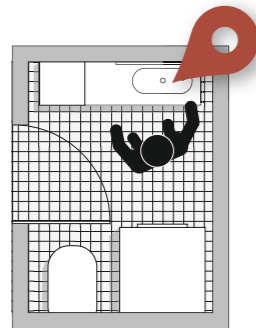

MEMENTO

page 67/71/103/119/137

**\_EN** Do you have limited spaces? These solutions give you the option of having a top of reduced depth.

**\_DE** Ihr Platzangebot ist begrenzt? Bei diesen Lösungen haben Sie die Möglichkeit, eine Waschtischplatte mit verringerter Tiefe zu wählen.

**\_FR** Vous avez une petite pièce ? Ces solutions vous donnent la possibilité d'avoir un plan de toilette avec une profondeur réduite.

**\_ES** dispones de espacios contenidos estas soluciones te ofrecen la posibilidad de tener una encimera de profundidad reducida.

## HAI BISOGNO DI UNA SOLUZIONE AD ANGOLO?

DEVI RISOLVERE UN  
ANGOLO DEL TUO  
BAGNO E HAI POCO  
SPAZIO? ECCO I PIANI/  
LAVABO PERFETTI

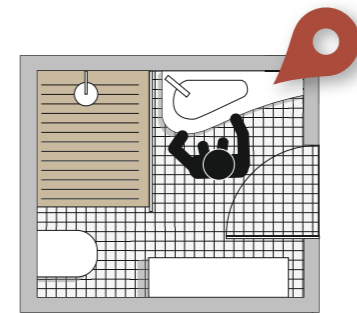

VERSA

page 67/137

**\_EN** Do you need a corner solution? Do you need to find a solution for a corner of your bathroom but have limited space? Here are the ideal tops and sinks.

**\_DE** Benötigen Sie eine Ecklösung? Sie müssen eine Ecke Ihres Badezimmers nutzen und haben wenig Platz? Das sind die perfekten Waschtischplatten/Becken.

**\_FR** Vous avez besoin d'une solution en angle ? Vous devez aménager un angle de votre salle de bains et vous avez peu de place ? Voici des plans-vasques parfaits.

**\_ES** necesitas una solución de esquina? ¿debes solucionar una esquina de tu baño y dispones de poco espacio? aquí tienes las encimeras con lavabo perfectas.



## index



### **ACQUA e SAPONE**

page 17

Ante rientranti con taglio 45° e presa a gola.  
Retracting doors with 45° edge w/grip recess.  
Seitlich einschiebbare Türen mit 45°-Zuschnitt und Hohlkehle.  
Portes rentrantes avec chant à 45° et gorge  
Puertas escamoteables con corte de 45° y agarre por ranura

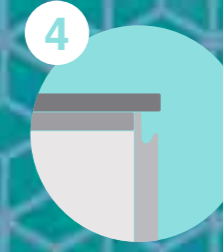

### **MEMENTO**

page 111

Anta con maniglia a gola sp 22 mm.  
Door with grip-recess handle Th. 22 mm.  
Tür mit Griffprofil St. 22 mm  
Porte avec poignée intégrée ép. 22 mm  
Puertas con tirador acanalado esp. 22 mm



### **LAPIS**

page 53

Ante con taglio 45° e presa a gola.  
Doors with 45° edge w/grip recess.  
Türen mit 45°-Zuschnitt und Hohlkehle.  
Portes avec chant à 45° et gorge  
Puertas con corte de 45° y agarre por ranura



### **VERSA**

page 135

Anta con maniglia a gola sp 22 mm.  
Door with grip-recess handle Th. 22 mm.  
Tür mit Griffprofil St. 22 mm  
Porte avec poignée intégrée ép. 22 mm  
Puertas con tirador acanalado esp. 22 mm



### **45**

page 77

Fianchi e ante a 45°, presa a gola.  
Side panels and doors with 45° edge, w/grip recess.  
Seitenwände und Türen mit 45°-Zuschnitt, Hohlkehle.  
Côtés et portes à 45°, gorge costados y puertas de 45°, agarre por ranura



### **CAMPUS**

page 151

fianchi ed anta bombati spessore massimo mm. 40, presa a gola, side panels and curved door max. Th 40 mm, w/ grip recess.  
Seitenwände und gewölbte Tür Stärke max. 40 mm, Hohlkehle.  
Côtés et portes bombés épaisseur maximale 40 mm, gorge  
Costados y puerta curvados, espesor máximo 40 mm, agarre por ranura





## ACQUA e SAPONE

design MONICA GRAFFEO

**IL PROGETTO ACQUA E SAPONE BATH PRENDE IN CONSIDERAZIONE GLI SPAZI FUNZIONALI E COMPATTI DELLA CASA, BAGNO E LAVANDERIA INSIEME, BAGNO OSPITI, OFFRENDO SOLUZIONI FUNZIONALI E CARATTERIZZANTI, CON LO SCOPO DI DARE IDENTITÀ E DIGNITÀ A QUESTI SPAZI MOLTO UTILI.**

**\_EN** The "Acqua e Sapone" project provides compact functional spaces in the house, bathroom/laundry room, and guest bathroom, offering distinct functional solutions, intended to give identity and dignity to these very useful spaces.

**\_DE** Der Entwurf Acqua e Sapone Bath konzentriert sich auf die Funktionsräume des Heims wie ein auch als Waschküche genutztes Bad oder ein Gäste-WC und bietet zweckmäßige und originelle Lösungen, die diesen äußerst nützlichen Orten Identität und Würde verleihen.

**\_FR** Le projet « Acqua e sapone bath » prend en considération les espaces étroits de la maison, la salle de bains et la buanderie ensemble ou la salle de bains pour les invités, en offrant des solutions fonctionnelles et distinctives ayant pour but de donner une identité et une dignité à ces espaces très utiles.

**\_ES** El proyecto acqua e sapone bath toma en consideración los espacios funcionales y compactos de la casa, baño y lavandería juntos, aseo, ofreciendo soluciones funcionales y características, a fin de aportar carácter y decoro a estos espacios tan útiles.



## ACQUA e SAPONE/CONSOLLE E PANCA LAVABO

\_Washbasin unit and washbasin bench  
\_Waschtischauflage und Bank für Waschtisch  
\_Table et meuble sous-vasque  
\_Consola y banco lavabo

**COMP. 1/A L.90 P. 54 H.190**

**\_IT** Laccato Bianco opaco 9003.

**\_EN** Matt White 9003 lacquer.

**\_DE** Weiß matt lackiert 9003.

**\_FR** Laqué blanc 9003 mat.

**\_ES** Lacado Blanco mate 9003.

### CONSOLLE LAVABO

Wash basin unit  
Waschtischauflage  
Table sous-vasque  
Consola lavabo

L. **90** cm  
P. **54,5** cm  
H. **84** cm

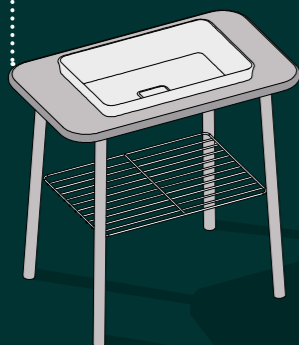

### PANCA LAVABO

Wash basin bench  
Bank für Waschtisch  
Meuble sous-vasque  
Banco lavabo

L. **120** cm  
P. **50** cm  
H. **70** cm

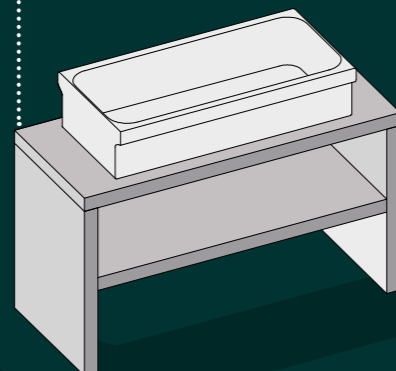

**\_IT** Panca a ponte disponibile in melaminico e laccato. Panca 4 gambe solo in laccato.

**\_EN** Bench available in melamine and lacquer finishes. Bench with 4 legs available in lacquer only.

**\_DE** Bank Melamin oder lackiert. Bank mit 4 Füßen nur lackiert.

**\_FR** Meuble sous-vasque décliné en mélaminé ou laqué. Table sous-vasque uniquement en laqué.

**\_ES** Banco disponible en melamina o lacado. Banco con 4 patas solo lacado.

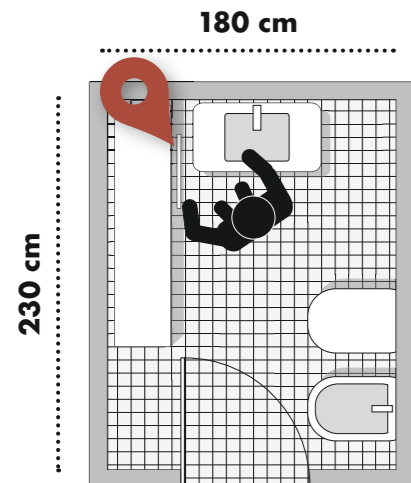

\_Soluzione con griglia attrezzata su armadio scorrevole slim.  
 \_Solution with an accessorised rack on a slim sliding door wardrobe.  
 \_Lösung mit ausgestattetem hängegitter auf schrank mit schiebetür slim.  
 \_Solution avec grille aménagée sur armoire coulissante Slim.  
 \_Solución con rejilla equipada para armario corredero Slim.

1/A

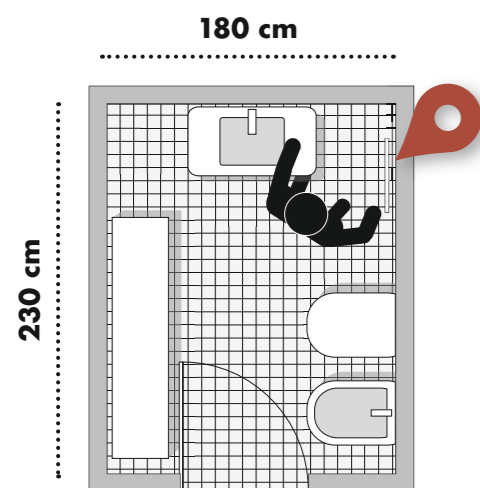

\_Soluzione con griglia attrezzata a muro.  
 \_Solution with a wall-mounted accessorised rack.  
 \_Lösung mit ausgestattetem hängegitter zur wandbefestigung.  
 \_Solution avec grille aménagée fixée au mur.  
 \_Solución con rejilla equipada de pared.

1/B

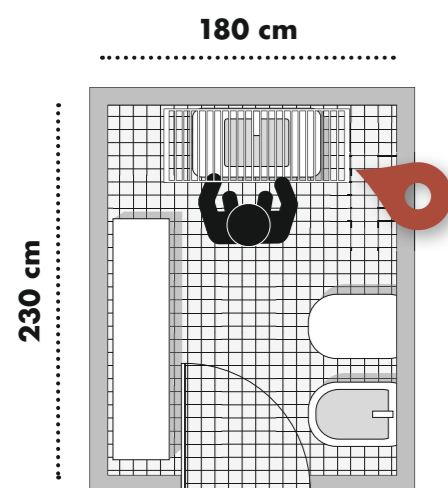

\_Soluzione con griglia attrezzata a soffitto.  
 \_Solution with a ceiling-mounted accessorised rack.  
 \_Lösung mit ausgestattetem hängegitter zur deckenbefestigung.  
 \_Solution avec grille aménagée fixée au plafond.  
 \_Solución con rejilla equipada de techo.

1/C



**COMP. 1/B L.90 P. 54 H. 200**

\_IT Laccato Bianco opaco 9003.

\_EN Matt White 9003 lacquer.

\_DE Weiß matt lackiert 9003.

\_FR Laqué blanc 9003 mat.

\_ES Lacado Blanco mate 9003.







**GRIGLIA ATTREZZATA  
A SOFFITTO**

- \_Ceiling-mounted accessorised rack.
- \_Ausgestattetes Hängegitter zur Deckenbefestigung
- \_Grille aménagée fixée au plafond
- \_Rejilla equipada de techo







\_Elemento in griglia che può essere utilizzato per appendere di tutto, attrezzato con ganci e vaschette porta accessori.  
 \_A rack element, for hanging everything, is accessorised with hooks and accessory trays.  
 \_Mit Haken und Ablageschalen ausgestattetes Element aus Gitterdraht, das zum Aufhängen der unterschiedlichsten Dinge genutzt werden kann.  
 \_Élément grillagé pouvant être utilisé pour accrocher n'importe quoi et équipé de crochets et de bacs de rangement.  
 \_Elemento de rejilla que se puede utilizar para colgar cualquier cosa, provisto de colgadores y cubetas portaobjetos.

**COMP. 1/A L.90 P. 54 H.190**

\_IT Laccato Bianco opaco 9003. Armadio scorrevole L.100 P. 36 H. 209.

\_EN Matt White 9003 lacquer. Sliding door wardrobe W.100 D. 36 H. 209.

\_DE Weiß matt lackiert 9003. Schrank mit Schiebetür B.100 T. 36 H. 209.

\_FR Laqué Blanc 9003 mat. Armoire coulissante L.100 P. 36 H. 209.

\_ES Lacado Blanco mate 9003. Armario corredero A. 100 P. 36 H. 209.





**Comp. 2 L.90+50+50 P. 54 H.190**

**\_IT** Laccato Rosso Rubino  
O241 opaco.

**\_EN** Matt Ruby Red O241  
lacquer.

**\_DE** Rubinrot matt lackiert  
O241.

**\_FR** Laqué rouge rubis O241  
mat.

**\_ES** Lacado Rojo Rubí O241  
mate.



**SOLUZIONE SALVASPAZIO  
PENSILI SOPRA WC**

\_Wall-mounted space-saving unit above  
the toilet

\_Lösung mit platzsparenden  
Hängeelementen über dem WC

\_Solution gain de place avec éléments  
suspendus au-dessus du WC

\_Solución salvaspacio con armarios  
sobre inodoro





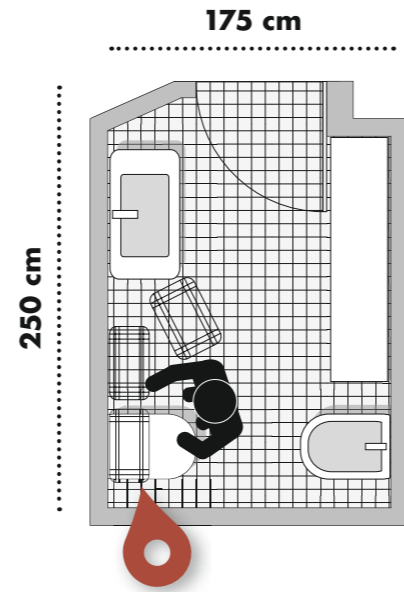

**SPECCHIO CON  
LAMPADA INTEGRATA**

- ..Mirror with integrated light.
- ..Spiegel mit eingebauter Lampe
- ..Miroir avec éclairage incorporé
- ..Espejo con luz integrada





## ACQUA e SAPONE / CESTI E PENSILI IN FILO METALLICO

\_Metal wire baskets and wall units  
 \_Körbe und Hängeelemente  
 \_Paniers et éléments à suspendre en fil métallique  
 \_Cestos y armarios de rejilla metálica

### CESTO PORTABIANCHERIA

Laundry basket  
 Wäschekorb  
 Panier à ligne  
 Cesto para la ropa

L. 50 cm  
 P. 40 cm  
 H. 29 cm

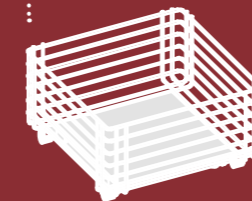

### PENSILI / PENSILI A SPECCHIO

Wall racks/Mirror wall units  
 Hängeelemente/Spiegelschränke  
 Éléments à suspendre/avec miroir  
 Armarios/Armarios con espejo

L. 50/80/100 cm  
 P. 19/23 cm  
 H. 31/50 cm

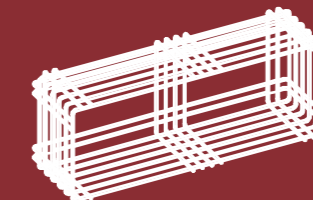
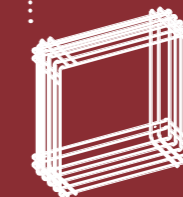

### GRIGLIA ATTREZZATA

Accessorised rack  
 Ausgestattetes Hängegitter  
 Grille aménagée  
 Rejilla equipada

L. 45 cm  
 P. 2 cm  
 H. 120 cm

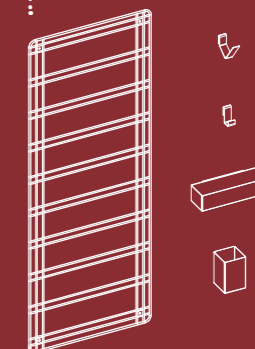



## ACQUA e SAPONE

Comp. 3 L.120 P.50 H.180

\_IT Olmo Bianco. Colonna porta lavatrice L.80 P.70 H.191.

\_EN White Elm. Pillar washing machine unit W.80 D.70 H.191.

\_DE Ulme Weiß. Waschmaschinen-Hochschrank B.80 T.70 H.191.

\_FR Orme blanc. Colonne pour lave-linge L.80 P.70 H.191.

\_ES Olmo Blanco. Columna para lavadora A. 80 P.70 H.191.



.....○  
\_Soluzione contenitiva sopra i sanitari  
\_Storage solution above the sanitary fittings  
\_Stauraumlösung über den Sanitärelementen  
\_Solution de rangement au-dessus des sanitaires  
\_Solución para el almacenamiento sobre los sanitarios



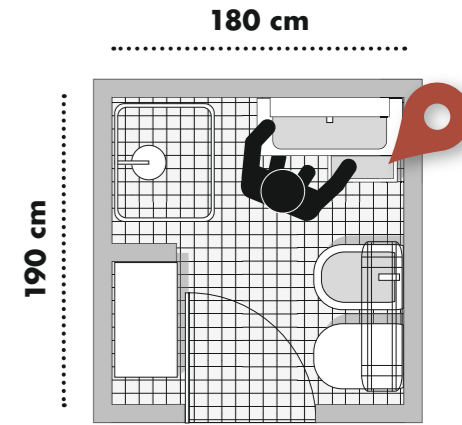

**CASSETTONE  
ESTRAIBILE /  
ALZATA BIMBO  
CON PIANO  
ANTISCIVOLO**

- \_Pullout deep drawer/children's step element with non-slip top.
- \_ Ausziehbarer Schubkasten / Erhöhung für Kinder mit rutschfester Platte.
- \_Grand tiroir / rehausseur pour enfant avec dessus anti-glisse.
- \_Gaveta extraíble/banqueta niño con superficie antideslizante.



## ACQUA e SAPONE/COLONNE E BASI

\_Programma elementi ante rientranti  
\_Units with retracting door programme  
\_Elemente mit seitlich einschiebbaren Türen  
\_Programme d'éléments avec portes rentrantes  
\_Columnas y muebles

### COLONNE

Tall units  
Hochschränke  
Colonnes  
Columnas

L. **42,5** cm  
P. **60/70** cm  
H. **191** cm

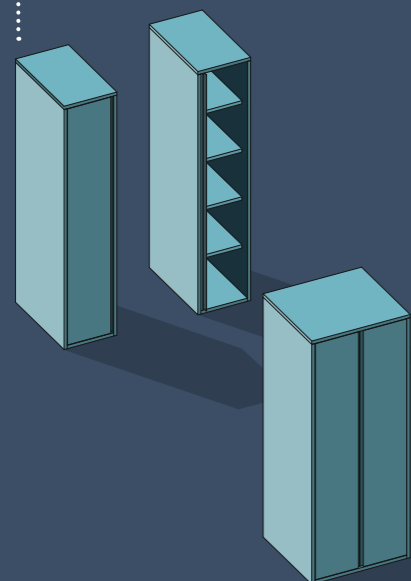

### COLONNE

Tall units  
Hochschränke  
Colonnes  
Columnas

L. **80** cm  
P. **60/70** cm  
H. **191** cm

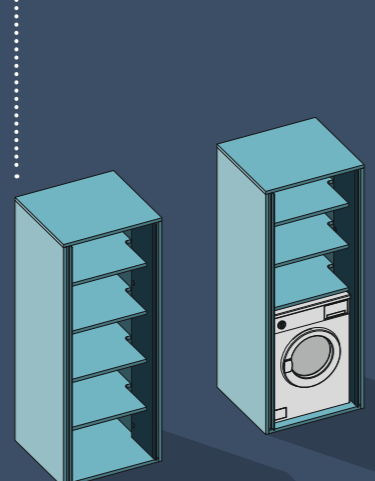

### BASI

Base units  
Unterschranke  
Meubles bas  
Muebles

L. **80** cm  
P. **50/60/70** cm  
H. **89** cm

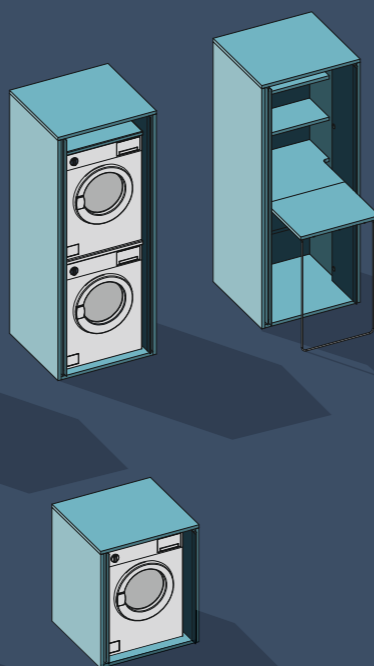

\_Appendiabiti estraibile  
\_Extractable clothes  
hanging rack  
\_Ausziehbarer  
Kleideraufhänger  
\_Porte-cintres extractible  
\_Perchero extraíble

\_Le ante scorrevoli del progetto lavanderia, vengono riprese anche in questa versione bagno con lo scopo di recuperare spazio e creare ordine.  
\_The sliding doors of the laundry project are also repeated in this bathroom version to recover space and keep everything tidy.  
\_Die Schiebetüren des Waschküchenentwurfs werden auch in dieser Badversion eingesetzt, um Platz zu sparen und Ordnung zu schaffen.  
\_Les portes coulissantes du projet buanderie sont également reprises dans cette version de salle de bains dans le but de récupérer de la place et de donner un sens d'ordre.  
\_Las puertas correderas del proyecto lavandería se encuentran también en esta versión de baño a fin de aprovechar el espacio y tenerlo todo en orden.



## ACQUA e SAPONE / SPECCHIERA STENDINO

\_Mirror wall unit / laundry rack  
\_Spiegelschrank mit Wäscheständer  
\_Armoire de toilette avec étendoir à linge  
\_Espejo con tendedero

### SPECCHIERA PENSILE STENDINO

Mirror wall unit / laundry rack  
Spiegelschrank mit Wäscheständer  
Armoire de toilette avec étendoir à linge  
Espejo con tendedero

L. 90 cm  
P. 10 cm  
H. 45 cm

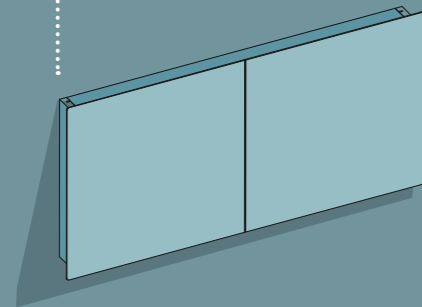

**\_IT** Innovativo specchio con stendibiancheria apribile, sgocciola direttamente sul lavabo.

**\_EN** Innovative mirror with extendible laundry rack which drips straight into the sink.

**\_DE** Innovativer Spiegel mit ausklappbarem Wäscheständer, der direkt über dem Waschbecken abtropft.

**\_FR** Innovante armoire de toilette avec étendoir ouvrable, égouttement directement au-dessus du lavabo.

**\_ES** Espejo innovador con tendedero que se abre, gotea directamente en el lavabo.

### 6 MT. DI FILO PER STENDERE

6 m hanging line  
6 m Draht zum Aufhängen  
6 m de corde à linge  
6 metros de hilo para tender

### SPECCHIO STENDINO

\_Mirror wall unit/ laundry rack  
\_Spiegelschrank mit Wäscheständer  
\_Armoire de toilette avec étendoir à linge  
\_Espejo con tendedero







**PANCA SEDUTA/  
ALZATA BAMBINO**

\_Bench seat/children's step element.  
\_Sitzbank/Erhöhung für Kinder  
\_Banc siège/rehausseur pour enfant  
\_Banco asiento/banqueta para niños

**COMP. 4 L.120 P.50 H.190**

\_IT Laccato Rosso Rubino  
O241 opaco/Olmo cacao.

\_EN Matt Ruby Red O241  
lacquer /Cocoa Elm.

\_DE Rubinrot matt lackiert  
O241/Ulme Kakao.

\_FR Laqué rouge rubis O241  
mat/Orme cacao.

\_ES Lacado Rojo Rubí O241  
mate/Olmo cacao.





## ACQUA e SAPONE/SPECCHIO FILO METALLICO

\_Metal wire mirror  
\_Hochschränke und Unterschränke  
\_Miroir en fil métallique  
\_Espejo de rejilla metálica

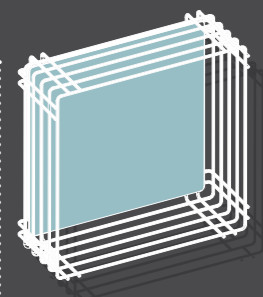

### SPECCHIO FILO METALLICO

\_Metal wire mirror  
\_Die Schiebetüren des Waschküchenentwurfs werden auch in dieser Badversion eingesetzt, um Platz zu sparen und Ordnung zu schaffen  
\_Miroir en fil métallique

L. 50 cm  
P. 19 cm  
H. 50 cm



### LAMPADA A LED ORIENTABILE CON CALAMITA

\_Adjustable LED light with magnet  
\_Verstellbare Led-Lampe mit Magnet  
\_Spot à leds orientable avec aimant  
\_Luz de leds orientable con imán





## ACQUA e SAPONE

COMP. 5 L.200 P.60 H.190

\_IT Laccato Canapa O62  
opaco/Olmo corda.

\_EN Matt Hemp O62  
lacquer/Cord Elm.

\_DE Waschtischplatte aus  
Korakril T. 60 mit integriertem  
Becken.

\_FR Laqué chanvre O62 mat/  
Orme corde.

\_ES Lacado Cáñamo O62  
mate/Olmo cuerda.



## CASSETTONI ESTRAIBILI SU RUOTE

\_Extractable drawers on wheels  
\_Ausziehbare Schubkästen auf Rollen  
\_Grands tiroirs sur roulettes  
\_Gavetas extraíbles con ruedas



**PIANO IN KORAKRIL™/  
VERSATILITÀ MASSIMA/  
INCOLLATO SUL POSTO/  
SENZA LIMITI DI MISURA/  
INALTERABILE ALLA LUCE/  
RIPRISTINABILE/  
ATOSSICO**

\_Korakril™ top/ maximum  
versatility/ glued into place/  
unlimited size/ light-resistant /  
restorable / non-toxic.

\_Waschtischplatte aus  
Korakril™/ höchste  
Vielseitigkeit/ wird vor  
Ort verklebt/ ohne  
Größeneinschränkungen/  
lichtbeständig/ behandelbar/  
ungiftig.

\_Plan en Korakril™/  
polyvalence maximale/ collé  
sur place/ aucune limite de  
dimensions / inaltérable à la  
lumière/ réparable/ atoxique.

\_Encimera de Korakril™/  
máxima versatilidad/  
pegada in situ/ medidas sin  
límites/ inalterable a la luz/  
arreglable/ atóxica.

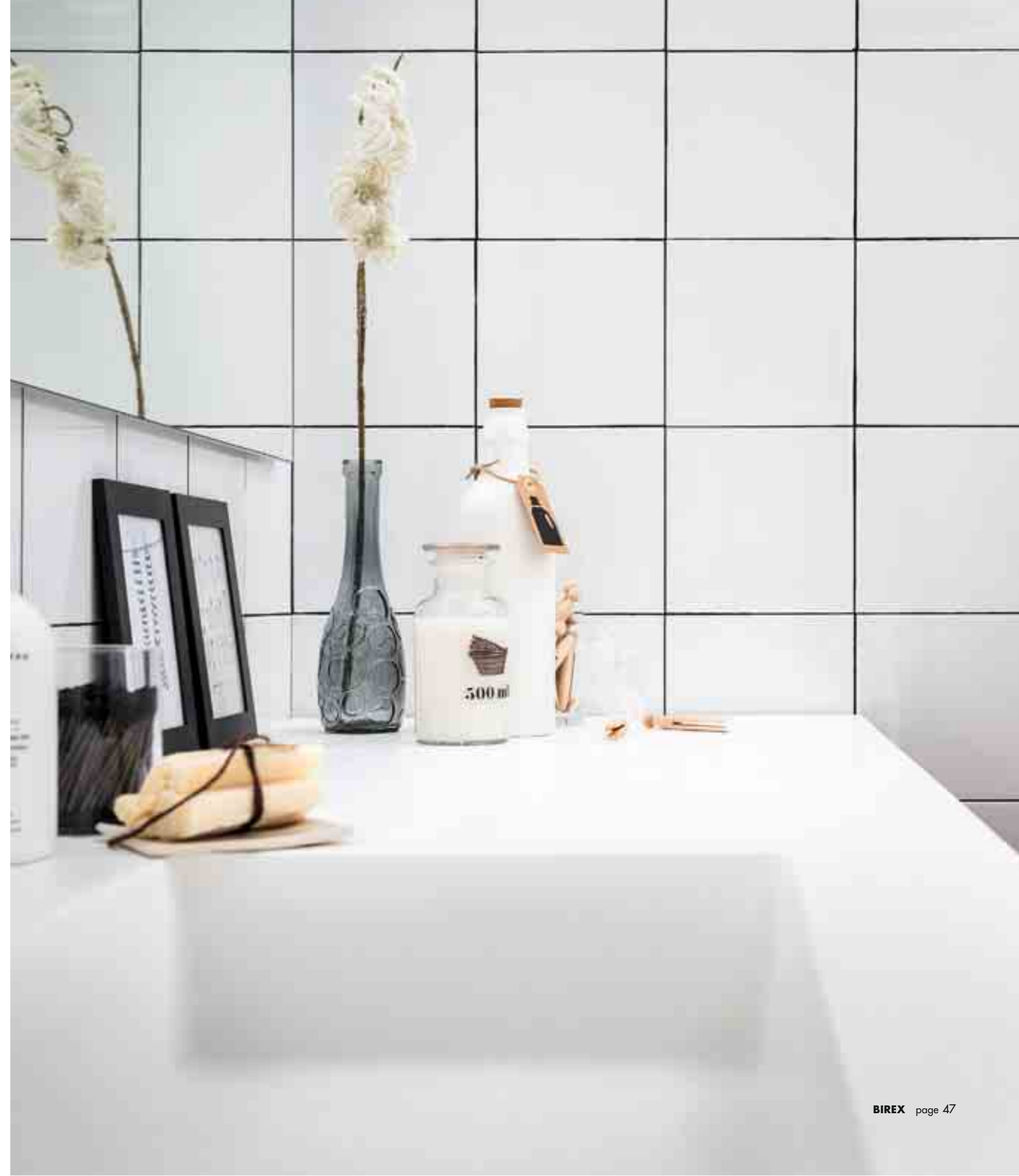



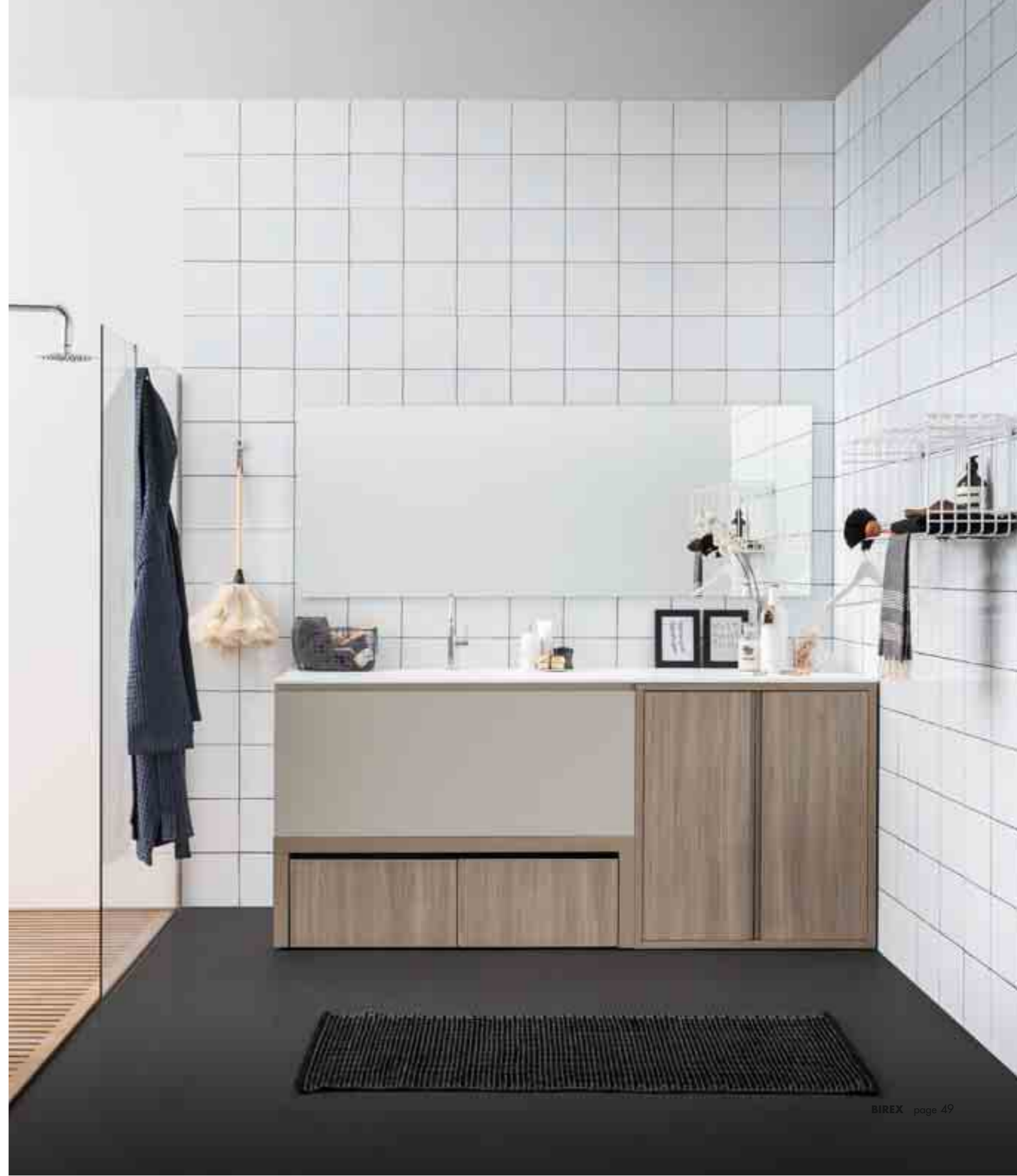
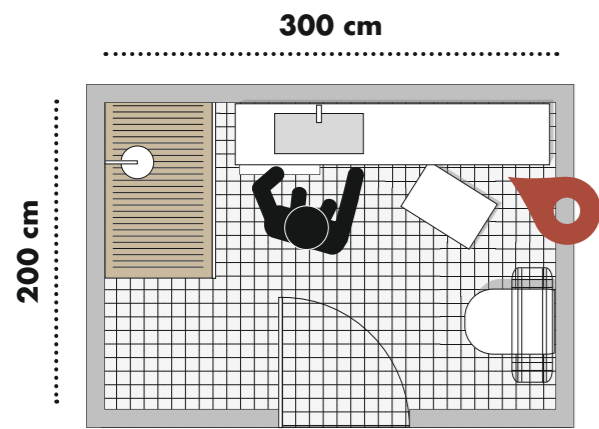

## ACQUA e SAPONE

### PIANO IN KORAKRIL™ P.60 CON LAVABO INTEGRATO

- \_Korakril™ top D.60 with built-in sink
- \_Waschtischplatte aus Korakril™
- \_T. 60 mit integriertem Becken
- \_Plan en Korakril™ P.60 avec vasque intégrée
- \_Encimera de Korakril™ p.60 con lavabo integrado

### CASSETTONI ESTRAIBILI SU RUOTE

- \_Pullout deep drawers on wheels
- \_Ausziehbare Schubkästen auf Rollen
- \_Grands tiroirs sur roulettes
- \_Gavetas extraíbles con ruedas

### ATTREZZATURA INTERNA CASSETTI

- \_Internal accessories for drawers
- \_Innenausstattung für Schubladen
- \_Aménagement intérieur pour tiroirs
- \_Equipamiento interior de cajones







## LAPIS

design **R.S. BIREX**

**PROGRAMMA ARREDI PER LA ZONA BAGNO PRATICO,  
SEMPLICE ED ATTUALE CON PRESA A 45° SULL'ANTA E GOLA.  
ABBINABILE CON ALTRI PROGRAMMI MINIMA, IDROBOX,  
ACQUA E SAPONE, CREA AMBIENTI COORDINATI.**

**\_EN** A furniture project for the bathroom that is practical, simple and up-to-date, with 45° edge on doors and grip recess. It can be combined with other projects such as "Minima", "Idrobox" and "Acqua e Sapone" to create coordinated spaces.

**\_DE** Ein praktisches, einfaches und aktuelles Einrichtungsprogramm für den Badbereich mit 45°-Kante auf der Tür und Hohlkehle. Lässt sich mit den Programmen Minima, Idrobox und Acqua e Sapone kombinieren, um harmonische Raumentwürfe zu schaffen.

**\_FR** Programme de meubles de salle de bains, pratique, simple et actuel avec chant de la porte à 45° et gorge. Utilisable avec les programmes Minima, Idrobox ou Acqua e Sapone pour créer des espaces coordonnés.

**\_ES** Programa de mobiliario para el baño práctico, sencillo y actual con agarre de 45° en la puerta y ranura. en combinación con otros programas minima, idrobox, acqua e sapone, da lugar a ambientes coordinados.



## LAPIS

COMP. 1 L.90 P.50 H.190

**\_IT** Laccato Bianco O9003 opaco. Pensili laccato Bianco O9003 opaco/Verde pompelmo O65.

**\_EN** Matt White O9003 lacquer. Wall units in matt White O9003 /Green Grapefruit O65 lacquer.

**\_DE** Weiß matt lackiert O9003. Wandschränke Weiß matt lackiert O9003/ Grapefruitgrün O65.

**\_FR** Laqué blanc O9003 mat. Éléments suspendus blanc O9003 mat/vert pamplemousse O65.

**\_ES** Lacado Blanco O9003 mate. Armarios lacados en Blanco O9003 mate/Verde pomelo O65.



### SOLUZIONI CONTENITIVE SOPRA I SANITARI

\_Storage solutions above the sanitary fittings  
 \_Stauraumlösungen über den Sanitärelementen  
 \_Solutions de rangement au-dessus des sanitaires  
 \_Soluciones para el almacenamiento sobre los sanitarios

250 cm

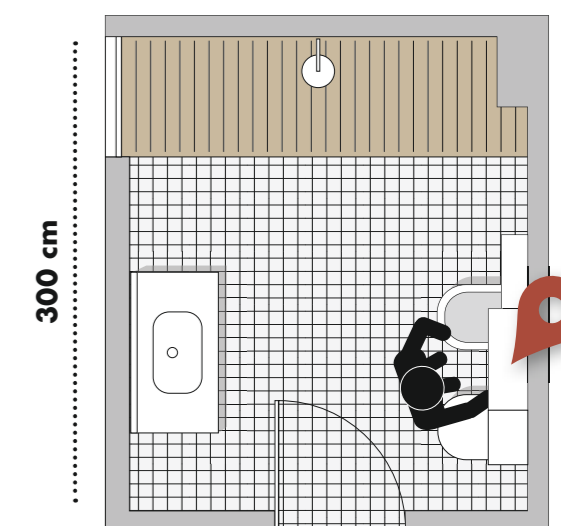





**SPECCHIO CON  
ILLUMINAZIONE  
LED PERIMETRALE**

- \_Mirror with perimeter LED lighting.
- \_Spiegel mit umlaufender LED-Beleuchtung
- \_Miroir avec éclairage périphérique à leds
- \_Espejo con luz de leds perimétrica



**PIANO INTEGRATO  
IN MINERALMARMO®**

- \_Built-in Mineralmarmo® top.
- \_Waschtischplatte mit integriertem Becken aus Mineralmarmo®
- \_Plan-vasque en Mineralmarmo®
- \_Encimera integrada de Mineralmarmo®

## LAPIS/MODELLI ABBINABILI

\_Matching models  
\_Kombinierbare Modelle  
\_Modèles utilisables  
\_Modelos combinables

### COMP. 2 L.135 P.50 H.200

\_IT laccato Rosso Acceso O3001 opaco/Olmo corda. Scarpiera Minima dimensioni: L.70+70 P.25 H.172.

\_EN Matt Red O3001 lacquer/Cord Elm. Shoe rack min. size: W.70+70 D.25 H.172.

\_DE Rot matt lackiert O3001/ Ulme Kacao Schuhrack Minima Maße: B. 70+70 T. 25 H. 172.

\_FR Laqué rouge O3001 mat/Orme corde. Range-chaussures Minima dimensions: L.70+70 P.25 H.172.

\_ES lacado Rojo O3001 mate/Olmo cuerda. Zapatero Minima medidas: A.70+70 P.25 H.172.

## LAPIS ABBINABILE CON: ACQUA e SAPONE IDROBOX MINIMA

\_Matching models: Acqua e Sapone, Idrobox, Minima.  
\_Kombinierbare Modelle: Acqua e Sapone, Idrobox, Minima.  
\_Lapis utilisable avec: Acqua e Sapone, Idrobox et Minima.  
\_Modelos combinables: Acqua e Sapone, Idrobox, Minima.



ACQUA e SAPONE



IDROBOX



MINIMA







### **SPECCHI DROP AGGREGABILI**

- \_Coordinated drop mirrors
- \_Aneinanderreihbare Spiegel Drop
- \_Miroirs Drop assemblables
- \_Espejos drop adosables

### **PIANO MINERMARMO® FINITURA PIETRA, LAVABO INTEGRATO FINITURA LISCIA PIÙ FACILE DA PULIRE**

- \_Minermarmo® top with stone finish, built-in washbasin with a smooth finish that is easy to clean
- \_Waschtischplatte aus Minermarmo® Ausführung Stone, integriertes Becken in glatter Ausführung für eine einfachere Reinigung
- \_Plan en Minermarmo® finition stone, vasque intégrée avec surface lisse plus facile à lave
- \_Encimera de Minermarmo® con acabado stone, lavabo integrado con acabado liso más fácil de limpiar





**NEW**

## PIANO MINERMARMO® FINITURA PIETRA

- \_Minermarmo® top with stone finish
- \_Waschtischplatte aus Minermarmo®  
Ausführung Stone
- \_Plan en Minermarmo® finition stone
- \_Encimera de Minermarmo® con  
acabado stone



## CASSETTO METALLICO AD ESTRAZIONE TOTALE CON CHIUSURA RALLENTATA BLUMOTION

- \_Full-extraction pullout metal  
drawer with Blumotion soft  
closing system.
- \_Schublade aus Metall mit  
Vollauszug und gebremstem  
Schließmechanismus  
Blumotion.
- \_Tiroir métallique à sortie  
totale avec amortisseur de  
fermeture Blumotion
- \_Cajón metálico de extracción  
total con cierre amortiguado  
blumotion



## LAPIS

COMP. 3 L.225 P.50 H.190

\_IT Olmo corda /laccato opaco Bianco 9003/verde petrolio O5021/O0246 Grigio Garda.

\_EN Cord Elm /matt White 9003/petrol green O5021/O0246 Garda Grey lacquer.

\_DE Ulme Kordel/matt lackiert Weiß 9003/Petrolgrün O5021/Gardagrau O0246.

\_FR Orme corde /laqué mat coloris blanc 9003/vert pétrole O5021/gris Garda O0246.

\_ES Olmo cuerda /lacado mate Blanco 9003/verde petróleo O5021/O0246 Gris Garda.

### PANCA: SOSTIENE LA BASE LAVABO ED È UNA PRATICA SEDUTA/ALZATA PER I BAMBINI

\_Bench: a support for the washbasin base unit and a practical seat/children's step element.

\_Bank: Trägt den Waschtisch-Unterschrank und ist eine praktische Sitzfläche/Erhöhung für Kinder.

\_Banc: il supporte l'élément sous-vasque et peut devenir un pratique siège/rehausseur pour les enfants.

\_Banco: soporta el mueble lavabo y constituye un práctico asiento/banqueta para los niños.

### SPECCHIO CON CORNICE BRILLANTE E LUCE LED

\_Mirror with chrome-plated frame and LED light

\_Spiegel mit verchromtem Rahmen und LED-Beleuchtung

\_Miroir avec encadrement chromé et éclairage à leds

\_Espejo con marco cromado y luz de leds

# LAPIS

COMP. 4 L.230 P.35/50 H.190

**\_IT** Olmo Bianco/laccato  
O0246 Grigio Garda opaco.  
Colonne dimensioni: L.150  
P.60 H.191.

**\_EN** White Elm / O0246  
matt Garda Grey lacquer.  
Pillar unit sizes: W.150 D.60  
H.191.

**\_DE** Ulme Weiß/Gardagrau  
matt lackiert O0246. Maße  
der Hochschränke: B. 150 T.  
60 H. 191.

**\_FR** Orme blanc/laqué gris  
Garda O0246 mat. Colonnes  
dimensions : L.150 P.60  
H.191.

**\_ES** Olmo Blanco/lacado  
O0246 Gris Garda mate.  
Medidas de las columnas:  
A.150 P.60 H.191.



## PENSILI SALVASPAZIO SOPRA WATER E BIDET

- \_Space-saving wall units  
above the toilet and bidet
- \_Platzsparende Wandschrän-  
ke über WC und Bidet
- \_Éléments gain de plan  
suspendus au-dessus du WC  
et du bidet
- \_Armarios salvaespacio sobre  
inodoro y bidé





**BASE LAVABO  
AD ANGOLO**

- \_ Corner washbasin unit
- \_ Eck-Waschtischunterschrank
- \_ Élément sous-vasque d'angle
- \_ Mueble lavabo de esquina

# LAPIS

COMP. 5 L.120+30 P.35/46 H.190

**\_IT** Olmo Bianco /laccato  
Bianco 9003 opaco.

**\_EN** White Elm /matt White  
9003 lacquer.

**\_DE** Ulme Weiß/Weiß matt  
lackiert 9003.

**\_FR** Orme blanc/laqué blanc  
9003 mat.

**\_ES** Olmo Blanco/lacado  
blanco 9003 mate.





## LAPIS/PIANI IN MINERALMARMO® CON CAMBIO PROFONDITÀ

\_Mineralmarmo® tops with different depths  
 \_Waschtischplatte aus Mineralmarmor mit unterschiedlicher Tiefe  
 \_Plans-vasque en Mineralmarmo® avec double profondeur  
 \_Encimeras de mármol sintético con cambio de profundidad

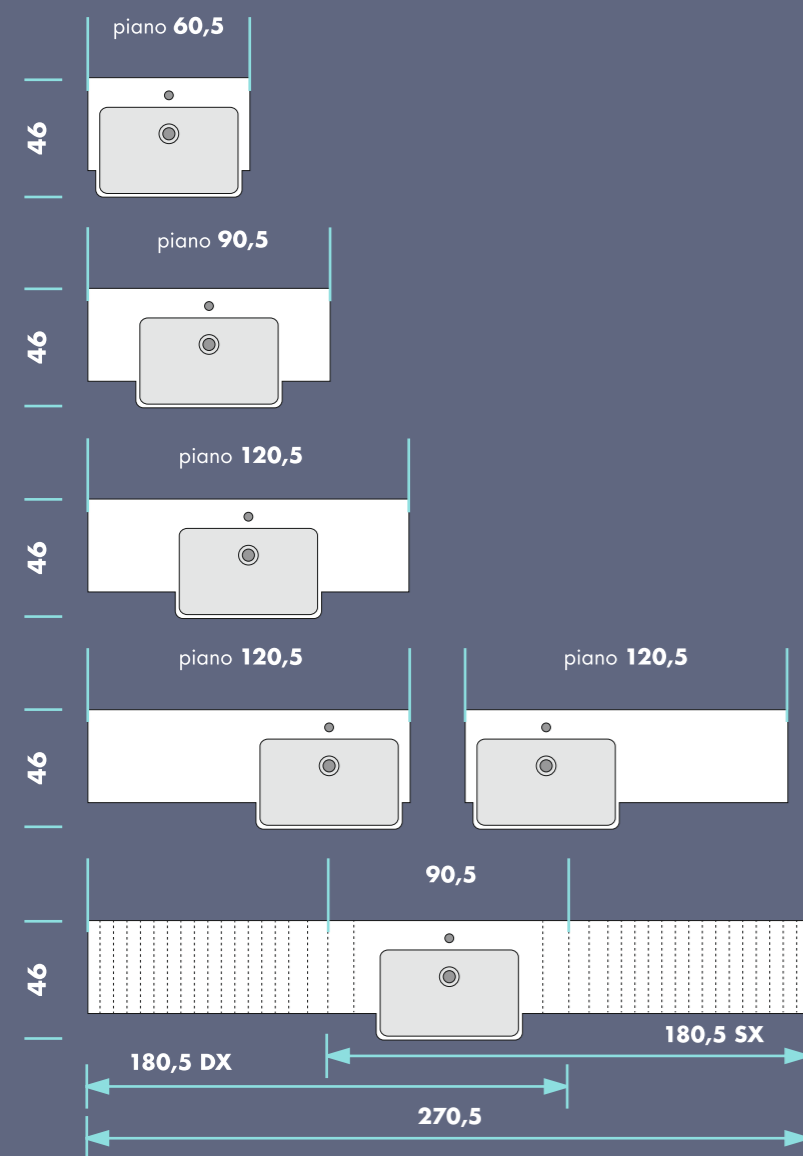

\_IT piano con cambio profondità, 35/46 adatto per spazi ridotti.

\_EN Top with different depths, 35/46, ideal for limited spaces.

\_DE Waschtischplatte mit unterschiedlicher Tiefe 35/46, passend für kleine Räume.

\_FR Plan-vasque avec double profondeur 35/46 idéal pour les espaces étroits.

\_ES encimera con cambio de profundidad, 35/46 idónea para espacios reducidos.

### PROFONDITÀ 35 CM

D.35 cm  
 Tiefe 35 cm  
 Profondeur 35 cm  
 profundidad 35 cm



## LAPIS/COLONNE

\_Vertical units  
\_Hochschränke  
\_Colonnes  
\_Columnas

### COLONNE SOSPESA H.141

Hanging pillar units  
Hochschränke  
Colonnes suspendues  
Columnas suspendidas

L. 30/45/60/75 cm  
P. 35/50/60 cm  
H. 141 cm

### COLONNE H.191

Tall units  
Hochschränke  
Colonnes  
Columnas

L. 30/45/60/75/90 cm  
P. 35/50/60 cm  
H. 191 cm

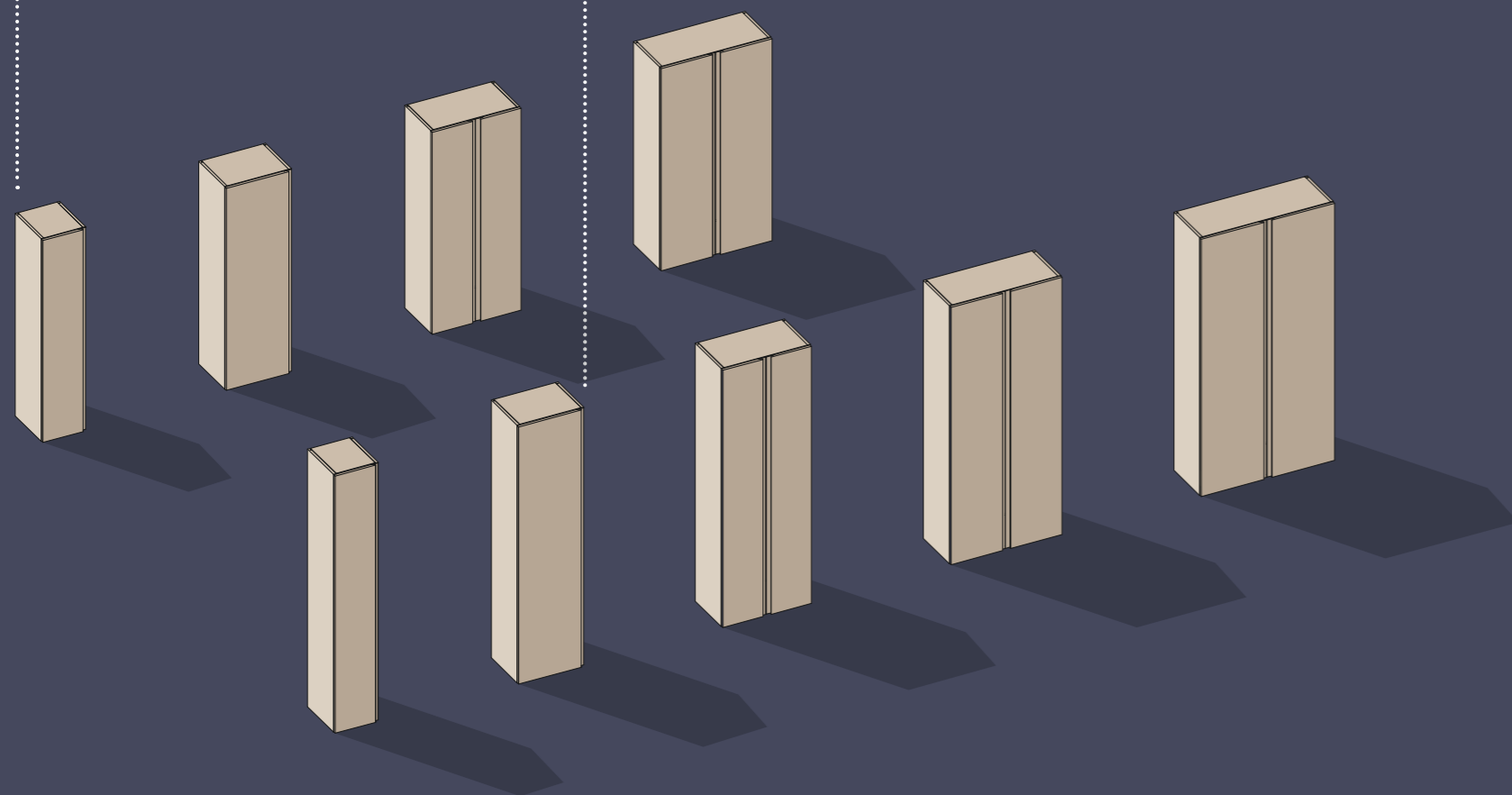





# 45

design R. S. BIREX

**UN PERFETTO CONNUBIO TRA DESIGN E FUNZIONALITÀ,  
PRENDE IL NOME DAL TAGLIO A 45°  
PRESENTE SU ANTE E FIANCHI,  
NUOVI MATERIALI E NUOVE SOLUZIONI COMPOSITIVE.**

**\_EN** A perfect combination of top-design and functionality thanks to 45° edges on doors and side panels, new materials and new compositions.

**\_DE** Diese perfekte Verbindung zwischen Design und Funktionalität erhält ihren Namen vom 45°-Zuschnitt der Türen und Seitenwände und überzeugt mit neuen Materialien und Anbaulösungen.

**\_FR** Parfaite union entre design et fonctionnalité, ce modèle prend le nom de la coupe à 45° présente sur les portes et sur les côtés. Nouveaux matériaux et nouvelles solutions d'agencement.

**\_ES** la combinación perfecta de diseño y funcionalidad, su nombre se debe al corte de 45° presente en las puertas y los costados, nuevos materiales y composiciones novedosas.

45

COMP. 1 L.225 P.50 H.190

\_IT Melaminico Rovere nodi naturale.

\_EN Knotted natural Oak melamine.

\_DE Melamin Eiche astig Natur.

\_FR Mélaminé Chêne à nœuds naturel.

\_ES Melamina Roble con nudos natural.





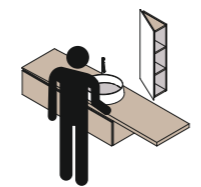
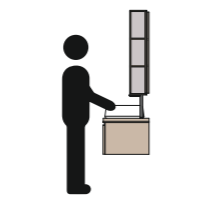
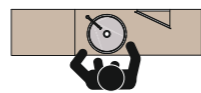
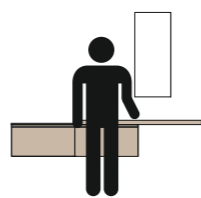

**SPECCHIO "SIDE",  
PROGETTATO  
PER STARE  
A LATO DEL  
LAVABO**

\_"Side" mirror, designed for positioning at the side of the washbasin.

\_Spiegel "Side", zur Montage seitlich des Waschtischs vorgesehen

\_Miroir "Side" conçu pour s'installer sur le côté de la vasque

\_Espejo "Side", proyectado para estar al lado del lavabo





45

COMP. 2 L.225 P.50 H.180



**\_IT** Melaminico finitura malta tortora/essenza rovere nodi.

**\_EN** Malta/ Dove Grey melamine finish/knotted Oak wood finish.

**\_DE** Melamin Ausführung Zement Taubengrau/Holz Eiche astig.

**\_FR** Nouvelle finitiion mélaminée mortier.

**\_ES** Melamina con acabado mortero tórtola/madera de roble con nudos.

**NEW**

**NUOVA FINITURA  
MELAMINICO  
MALTA**

- \_New Malta melamine finish
- \_Neue Melaminausführung Zement
- \_Nouvelle finitiion mélaminée mortier
- \_Nuevo acabado en melamina mortero





**LUCE  
PERIMETRALE  
LED**

- \_Perimeter LED light.
- \_Umlaufende LED-Beleuchtung
- \_Éclairage périphérique à leds
- \_Luz de leds perimétrica







**PIANO  
IMPIALLACCIATO  
CON VERNICIATURA  
IDROREPELENTE**

- \_Veneered top with water-resistant paint
- \_Furnierte Platte mit wasserabweisende Lackierung
- \_Plan plaqué avec vernissage hydrofuge
- \_Encimera enchapada con barnizadura hidrófuga





45

COMP. 3 L.180 P.50 H.200

\_IT Laccato O69 grigio  
polvere opaco.

\_EN Matt Dusty Grey O69  
lacquer.

\_DE Pulvergrau matt lackiert  
O69.

\_FR Laqué gris poudre O69  
mat.

\_ES Lacado O69 gris polvo  
mate.





## 45/BASI LAVABO

\_Washbasin bases  
 \_Waschtisch-Unterschänke  
 \_Éléments sous-vasque  
 \_Muebles lavabo

### BASI

Base units  
 Unterschänke  
 Éléments bas  
 Muebles

L. **30/45/60/75/90/105/120** cm  
 P. **35/50** cm  
 H. **24/36/48/60** cm

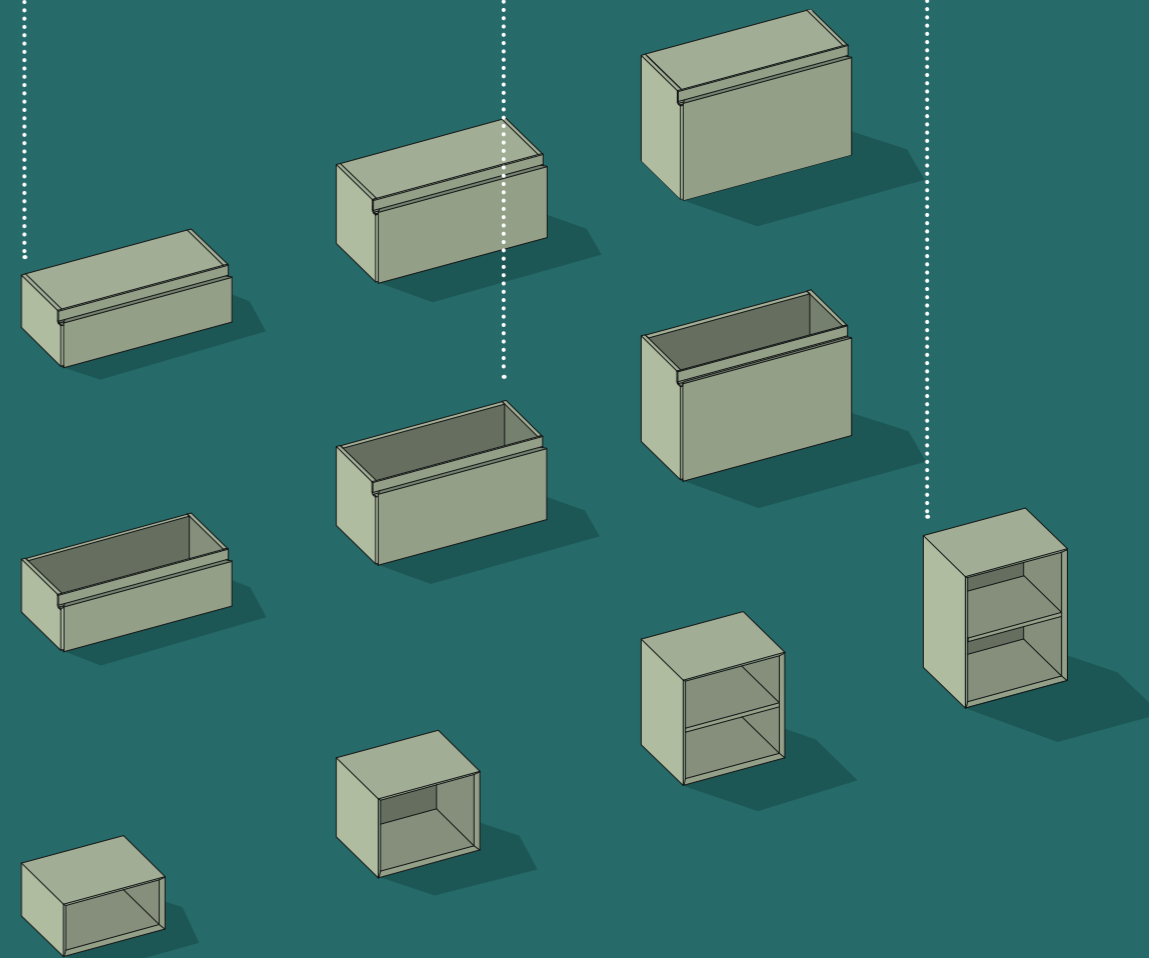

### BASI LAVABO

Washbasin bases  
 Waschtisch-Unterschänke  
 Éléments sous-vasque  
 Muebles lavabo

L. **60/75/90/105/120** cm  
 P. **35/50** cm  
 H. **24/36/48/60** cm

### BASI A GIORNO

Open units  
 Offene Fächer  
 Éléments ouverts  
 Compartimentos abiertos

L. **30/45** cm  
 P. **35/50** cm  
 H. **24/36/48/60** cm





**NEW**

320 cm

180 cm

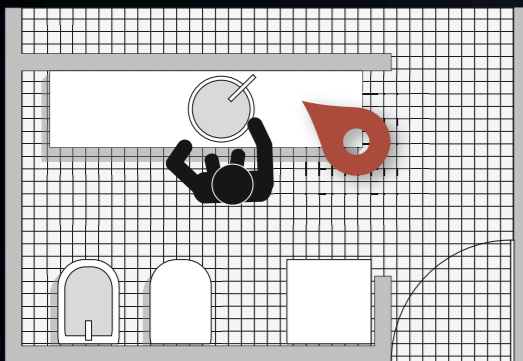

**PIANO IN  
GRANIGLIA  
VENEZIANA  
GREEN BELL**

- \_Green Bell Venetian marble grit top
- \_Waschtischplatte aus Marmorgranulat Veneziana Green Bell
- \_Plan en grenaille de marbre Veneziana Green Bell
- \_Encimera de granilla veneciana green bell





45

COMP. 4 L.165 P.50 H.180

\_IT Melaminico Rovere nodi naturale/ laccato Bianco 9003.

\_EN Knotted Natural Oak melamine/White 9003 lacquer.

\_DE Melamin Eiche astig Grau/ Melamin Weiß 9003.

\_FR Mèlaminé chêne à nœuds naturel/ laqué blanc 9003.

\_ES Melamina Roble con nudos natural/lacado Blanco 9003.

**BARRA PORTA SAPONE  
E ASCIUGAMANO**

- \_Soap and towel rail.
- \_Wandschränke
- \_Barre porte-savon et porte-serviettes
- \_Jabonera y toallero





## 45/VANI A GIORNO

\_Open units  
\_Offene Fächer  
\_Éléments ouverts  
\_Compartimentos abiertos

### PENSILI

Wall units  
Wandschränke  
Éléments à suspendre  
Armarios

L. 30/45/60/75/90 cm  
P. 20 cm  
H. 24 cm

### PENSILI

Wall units  
Wandschränke  
Éléments à suspendre  
Armarios

L. 30/45 cm  
P. 20 cm  
H. 36/48/60 cm

### BASI

Base units  
Unterschranke  
Éléments bas  
Muebles

L. 30/45 cm  
P. 35/50 cm  
H. 24/36/48/60 cm

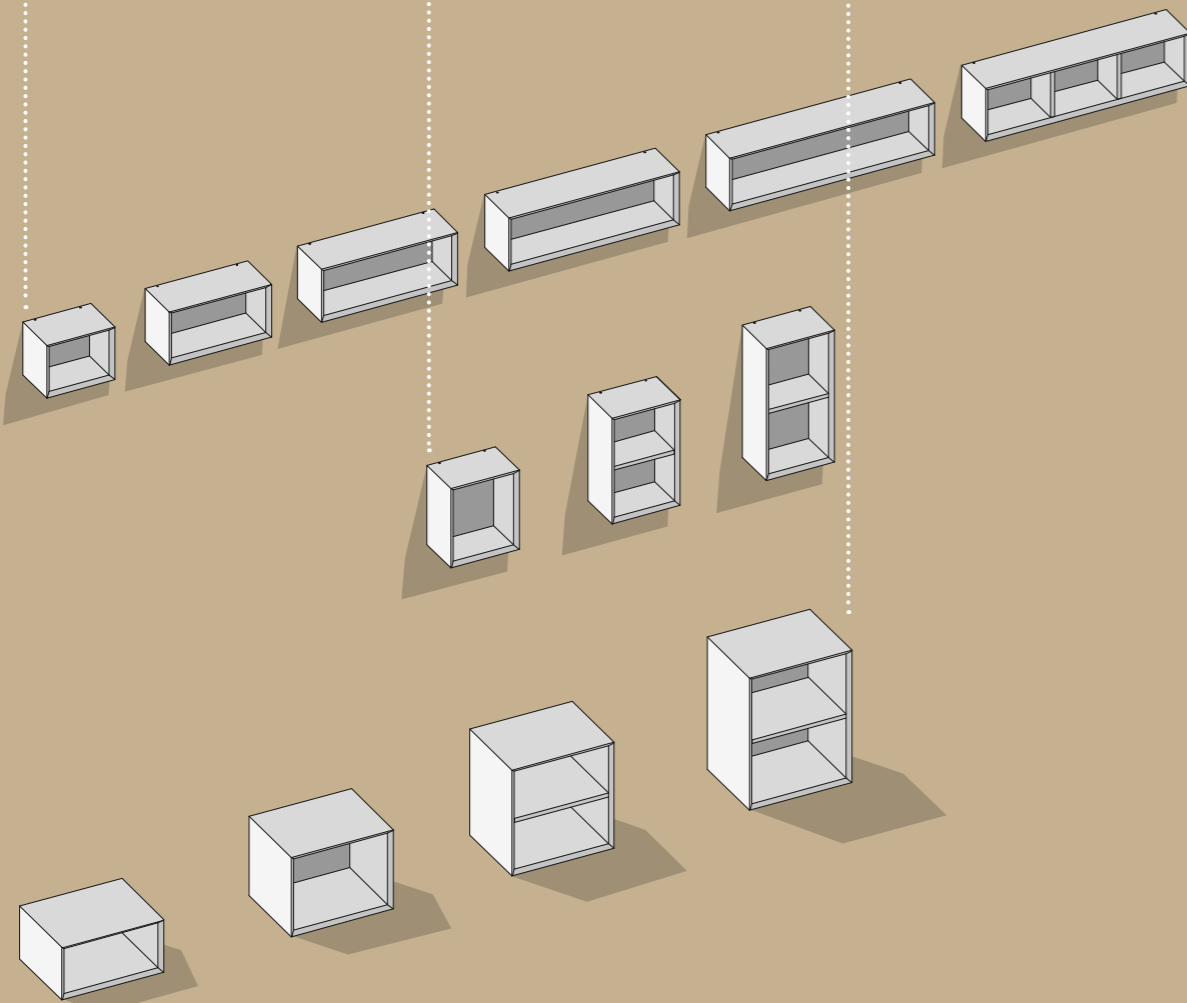

**\_IT** Melaminico Rovere nodi grigio/ laccato Bianco O9003.

**\_EN** Knotted Grey Oak melamine/ White lacquer O9003.

**\_DE** Melamin Eiche astig Grau/ Lackiert Weiß O9003.

**\_FR** Mé laminé chêne à nœuds gris/ Laqué blanc O9003.

**\_ES** Melamina roble con nudos gris/Lacado blanco O9003.



**CONTENIMENTO MASSIMO CON PENSILI E BASI**

- \_Maximum storage space with wall units and base units
- \_Maximales Stauraumangebot mit Wand- und Unterschränken
- \_Rangement maximal avec les éléments bas et suspendus
- \_Máximo almacenamiento con armarios y muebles

**GRANDE PIANO DI LAVORO E DI APPOGGIO**

- \_Large worktop and surface
- \_Große Arbeits- und Abstellfläche
- \_Grand plan de travail et de dépose
- \_Amplia superficie de trabajo y de apoyo

375 cm

200 cm

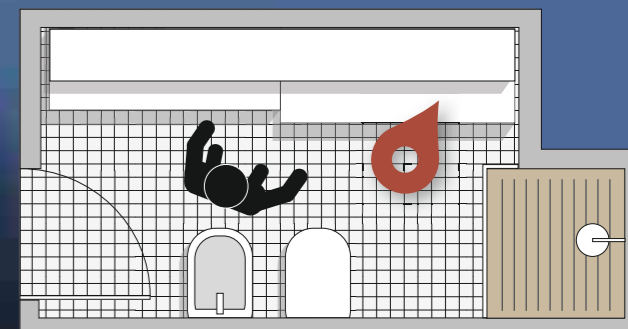



## BASE PORTA LAVATRICE/ ASCIUGATRICE

\_Washing machine/tumble dryer base unit  
\_Unterschrank für Waschmaschine/Wäschetrockner  
\_Élément bas pour lave-linge/sèche-linge  
\_Mueble para lavadora/secadora

L. 75 cm  
P. 50 /60 cm  
H. 89 cm

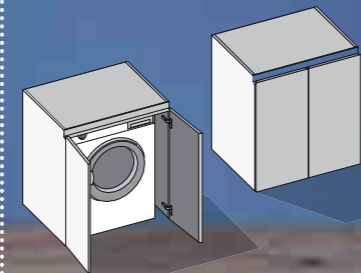

### LUCE LED INTERNA

\_Internal LED light  
\_Innere LED-Beleuchtung  
\_Éclairage intérieur à leds  
\_Luz de leds interior



### LUCE LED SOTTOPENSILE

\_Midway LED light  
\_LED-Beleuchtung unter dem Wandschrank  
\_Éclairage sous-haut à leds  
\_Luz de leds bajo armario

**IT** Melaminico Rovere nodi grigio/ melaminico Bianco.

**EN** Knotted Grey Oak melamine/ White melamine.

**DE** Melamin Eiche astig Grau/ Melamin Weiß.

**FR** Mé laminé chêne à nœuds gris/ mélaminé blanc.

**ES** Melamina roble con nudos gris/melamina blanca.



**SPECCHIO CON CORNICE  
BRILLANTE E LUCE LED**

- \_Mirror with chrome-plated frame and LED light
- \_Spiegel mit verchromtem Rahmen und LED-Beleuchtung
- \_Miroir avec encadrement chromé et éclairage à leds
- \_Espejo con marco cromado y luz de leds



**PIANO PIETRA  
NATURALE  
ANTIMACCHIA  
PROFONDITÀ  
RIDOTTA E GRANDE  
CAPIENZA**

- \_Stain-resistant natural stone top with reduced depth and high capacity.
- \_Waschtischplatte aus fleckenresistentem Naturstein mit verringerter Tiefe und großem Fassungsvermögen
- \_Plan en pierre naturelle traitée anti-taches à profondeur réduite et grande contenance
- \_Encimera de piedra natural a prueba de manchas de profundidad reducida y gran capacidad



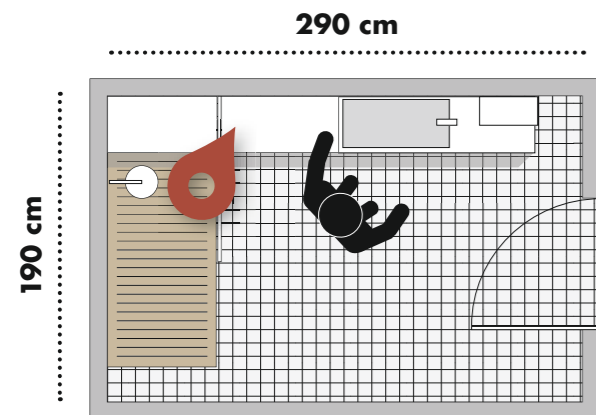

**FIANCO E ANTA A 45°  
FINITURA CON PORO A REGISTRO**

- \_Side panel and door with 45° edges, and register pore finish
- \_Seitenwand und Tür mit 45°-Zuschnitt, Ausführung mit Präzisionsmaserung
- \_Côté et porte à 45° finition structurée
- \_Costado y puerta de 45° con acabado poro sincronizado

## 45/SOLUZIONE PER HOTELLERIE

COMP. 7 L.180 H.220 P.50

\_IT Impiallacciato ER6 Rovere termotrattato.

\_EN Veneered heat-treated oak ER6.

\_DE Furniert Eiche thermobehandelt ER6.

\_FR Placage bois ER6 chêne thermo traité.

\_ES En chapa de roble termotratao ER&.

\_Soluzione per hotellerie  
\_Solution for projects  
\_Vorschlag für Objekt  
\_Solution pour hôtellerie  
\_Solucion para hoteles







# MEMENTO

design **IMAGO DESIGN**

**INCENTRATO SU SOLUZIONI INTELLIGENTI  
PER ARREDARE UN BAGNO IN PICCOLI SPAZI,  
PIACE ANCHE A CHI DISPONE DI STANZE GRANDI,  
UN PROGETTO MINIMALE ANTA A SPESSORE E MANIGLIA A  
GOLA INTEGRATA, ABBINABILE AL MODELLO VERSA E LOGIKA  
CON LA SUA VASTA GAMMA DI MISURE, PERMETTE OTTIMALI  
SOLUZIONI CONTENITIVE PER LA ZONA BAGNO.**

**\_EN** Focusing on smart solutions to furnish a bathroom in small spaces, it is also appreciated by those who have a large bathroom. This minimalist design project, with thick doors and integrated grip-recess handles, can be combined with the shaped Versa and Logika model with its wide range of sizes to provide excellent storage solutions in the bathroom.

**\_DE** Intelligente Lösungen für das Einrichten eines kleinen Badezimmers, die auch in großen Räumen eine gute Figur machen. Ein minimalistischer Entwurf mit Tür mit Griffprofil, der durch das reichhaltige Angebot an Maßen zum gerundeten Modell Versa Logika passt und viel Stauraum im Badbereich garantiert.

**\_FR** Se fondant sur des solutions intelligentes pour meubler les salles de bains de petites dimensions, ce modèle plaît également à ceux qui disposent de grandes pièces. Un projet minimal avec porte épaisse et poignée intégrée. Pouvant s'associer au modèle Versa et Logika aux lignes galbées et doté d'une vaste gamme de dimensions, il offre des solutions de rangement optimales pour la salle de bains.

**\_ES** Basado en las soluciones más inteligentes para decorar el baño de espacio reducido, satisface también quien dispone de un cuarto grande; un proyecto minimal con puerta gruesa y tirador acanalado integrado, que se combina con el modelo Versa y Logika con forma; por su extensa gama de medidas, ofrece las mejores soluciones de almacenamiento en el baño.



## MEMENTO/BASI E BASI LAVABO

COMP. 1 L.180 P.50 H.200

**\_IT** Laccato Bianco L 9003  
lucido/O0173 Bruciato  
opaco.

**\_EN** Gloss White L9003 /  
matt Burnt O0173 lacquer.

**\_DE** Weiß Hochglanz lackiert  
L 9003 /O0173 gebrannter  
Ton matt.

**\_FR** Laqué blanc L 9003  
brillant/marron brûlé O0173  
mat.

**\_ES** Lacado Blanco A 9003  
brillante/O0173 Marrón  
anaranjado mate.

### BASI

Base units  
Unterschränke  
Éléments bas  
Muebles

L. 30/45/60/75/90/105/120 cm

P. 35/50 cm

H. 24/36/48/60/72 cm

### BASI LAVABO

Washbasin units  
Waschtisch-Unterschränke  
Éléments sous-vasque  
Muebles lavabo

L. 60/75/90/105/120 cm

P. 35/50 cm

H. 24/36/48/60/72 cm

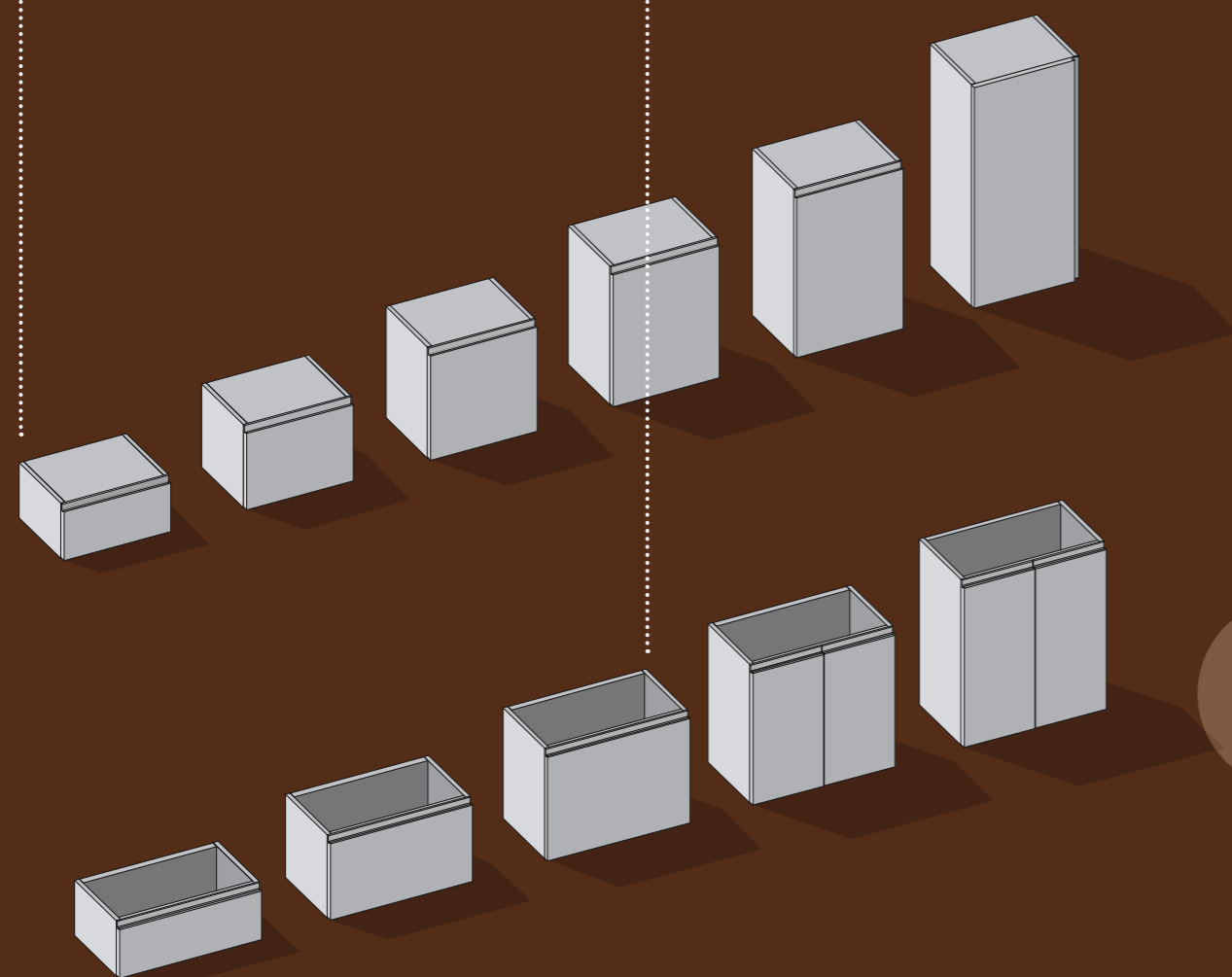

**\_IT** Possibilità di:  
1 anta o 2 ante normali  
o a ribalta, 1 o 2 cassettoni  
**\_EN** Available:  
1 door or 2 standard/flap  
doors, 1 or 2 deep drawers  
**\_DE** Mögliche Varianten:  
1 Tür oder 2 normale Türen  
oder Klapptüren, 1 oder 2  
Schubkästen  
**\_FR** Possibilité d'avoir :  
1 ou 2 portes battantes ou  
abattantes, 1 ou 2 grands  
 tiroirs  
o a ribalta, 1 o 2 cassettoni  
**\_ES** Posibilidad de:  
1 puerta o 2 puertas  
normales o abatibles, 1 ó 2  
 gavetas



### SPECCHIO "RANDOM", DISPONIBILE IN 6 COMPOSIZIONI/ MISURE

\_"Random" mirror, available in  
6 compositions/sizes

\_Spiegel "Random", in 6  
Zusammenstellungen / Maßen  
erhältlich

\_Miroir "Random", disponibles  
en 6 compositions/ dimensions

\_Espejo "Random", disponible  
en 6 composiciones/ medidas



**BASE PORTALAVABO  
CON PORTASALVIETTE**

- \_Washbasin unit with towel rail
- \_Waschtisch-Unterschrank mit Handtuchhalter
- \_Élément sous-vasque avec porte-serviettes
- \_Mueble lavabo con toallero





## MEMENTO/VANI A GIORNO

\_Open units  
\_Offene Fächer  
\_Éléments ouverts  
\_Compartimentos abiertos

### PENSILI

Wall units  
Wandschränke  
Éléments à suspendre  
Armarios

L. 30/45/60/75/90 cm  
P. 20 cm  
H. 24 cm

### PENSILI

Wall units  
Wandschränke  
Éléments à suspendre  
Armarios

L. 30/45 cm  
P. 20 cm  
H. 36/48/60 cm

### BASI

Base units  
Unterschränke  
Éléments bas  
Muebles

L. 30/45 cm  
P. 35/50 cm  
H. 24/36/48/60 cm

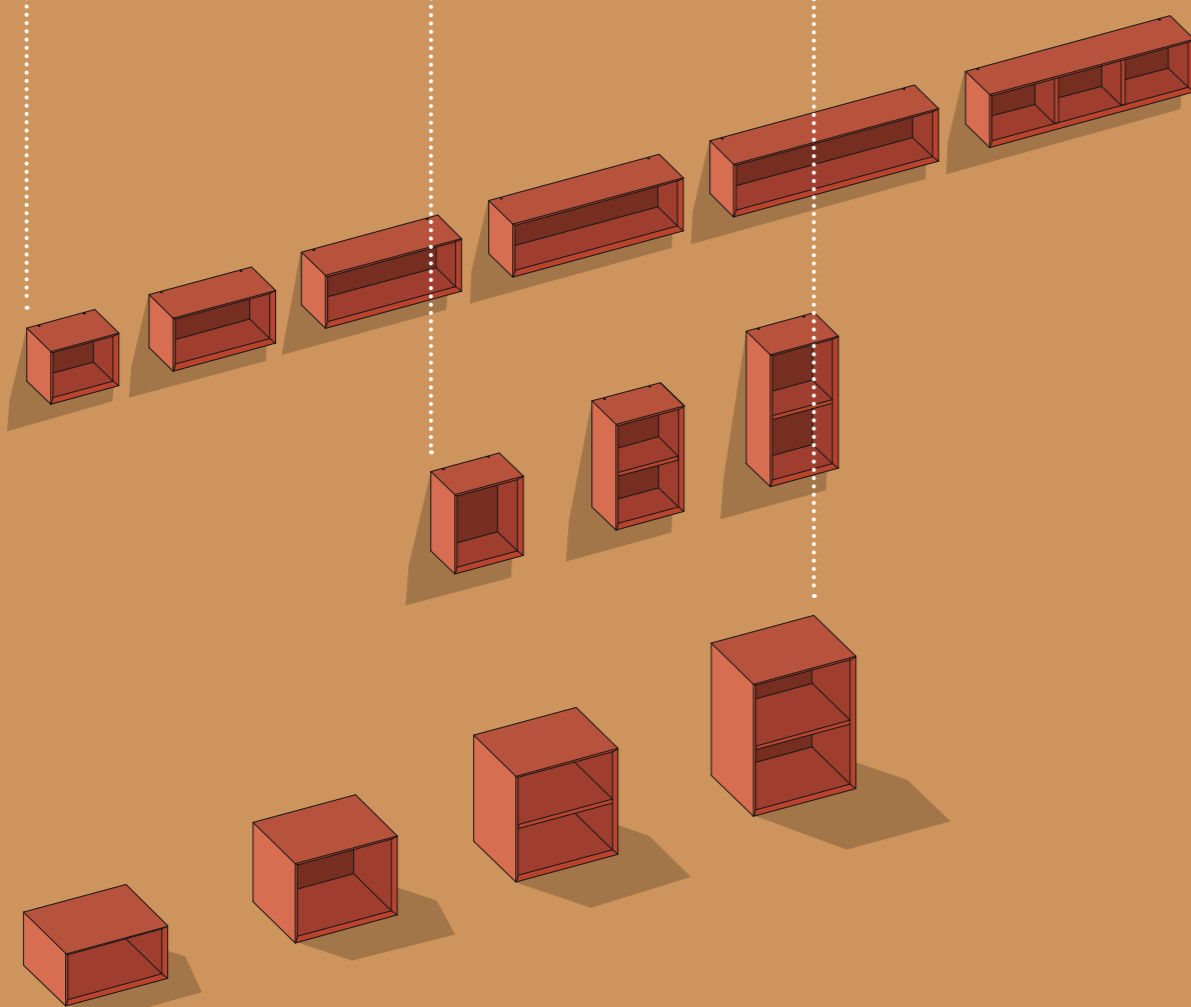

# MEMENTO

COMP. 2 L.135 P.35 H.200

**\_IT** Laccato 7035 grigio chiaro opaco.

**\_EN** Matt Light Grey 7035 lacquer.

**\_DE** Hellgrau matt lackiert 7035.

**\_FR** Laqué gris clair 7035 mat.

**\_ES** Lacado 7035 gris claro mate.

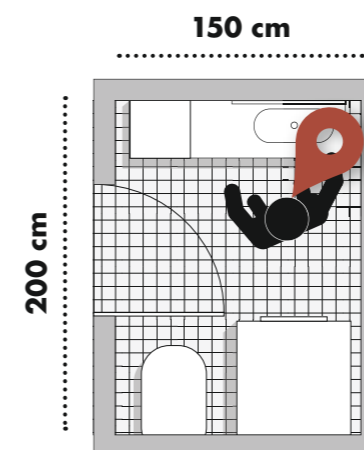





**PIANO IN  
KORAKRIL™  
INTEGRATO  
IN SOLI 35 CM.  
DI PROFONDITÀ**

- \_ Built-in Korakril™ top, D. 35 cm only
- \_ Waschtischplatte aus Korakril™ mit integriertem Becken mit nur 35 cm Tiefe
- \_ Plan-vasque en Korakril™ avec 35 cm de profondeur seulement
- \_ Encimera de Korakril™ integrada en tan sólo 35 cm de profundidad





**NUOVA BASE  
LAVABO  
MAXI CAPIENZA  
H. 60 CM,  
SOSPESA O CON  
BASAMENTO  
LACCATO**

**\_EN** New washbasin unit with maxi capacity H. 60 cm, wall-hung or with lacquered base unit.

**\_DE** Neuer geräumiger Waschtisch-Unterschrank H. 60 cm, wandhängend oder mit lackiertem Untergestell.

**\_FR** Nouvel élément sous-vasque grande contenance h. 60 cm, suspendu ou avec piètement laqué.

**\_ES** Nuevo mueble lavabo maxi capacidad h. 60 cm, suspendido o con base lacada.

## MEMENTO

**COMP. 3 L.150 P.50 H.200**

**\_IT** Laccato L64 giallo cromo.

**\_EN** Chrome Yellow L64 lacquer.

**\_DE** Chromgelb lackiert L64.

**\_FR** Laqué L64 jaune chrome.

**\_ES** Lacado A64 amarillo cromo.

### LUCE INTERNA CASSETTO

**\_Internal drawer light**

**\_Innenbeleuchtung für Schublade**

**\_Éclairage intérieur pour tiroir**

**\_Luz interior cajón**





## SPECCHI RANDOM

\_Random mirrors  
\_Spiegel Random  
\_Miroirs Random  
\_Espejos Random

**A**

L. **87** cm  
H. **88** cm

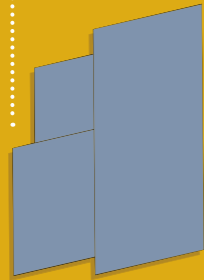

**B**

L. **101,5** cm  
H. **99** cm

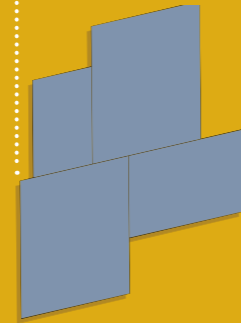

**C**

L. **112** cm  
H. **93** cm

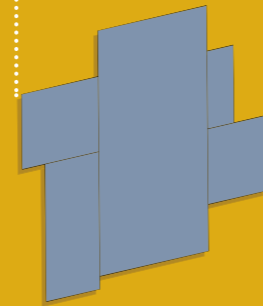

**D**

L. **120** cm  
H. **100** cm

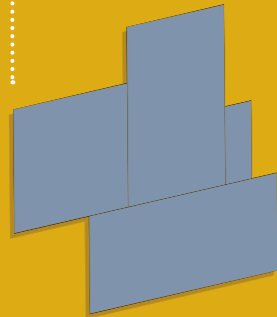

**E**

L. **144** cm  
H. **100** cm

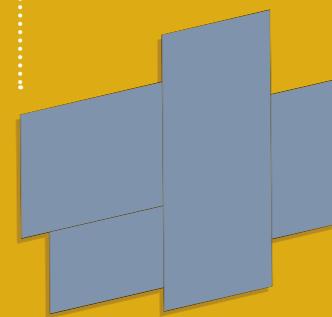

**F**

L. **165** cm  
H. **90** cm

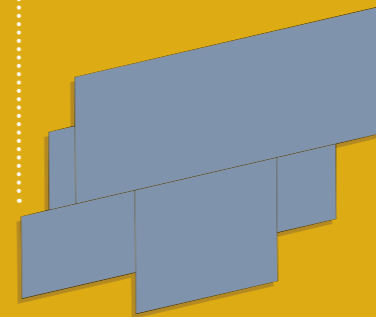

## LAMPADA LED CUBO, AFFIANCABILE ALLO SPECCHIO RANDOM

\_Cubo LED light, for positioning  
next to the Random mirror  
\_LED-Leuchte Cubo, neben  
Spiegel Random einsetzbar  
\_Applique à leds Cubo pouvant  
s'utiliser avec le miroir Random  
\_Luz de leds cubo, se puede  
instalar al lado del espejo random



# MEMENTO

COMP. 4 L.120 P.50 H.190

\_IT Laccato O63 Tortora opaco.

\_EN Matt Tortora O63 lacquer.

\_DE Tortora matt lackiert O63.

\_FR Laqué Tortora O63 mat.

\_ES Lacado O63 Tortora mate.

## SPECCHIO CONTENITORE "MIVEDO", GRAZIE ALLE TRE ANTE RIFLETTENTI PERMETTE UNA VISIONE TRIDIMENSIONALE

\_"Mivedo" storage mirror, with three reflective doors for a 3-D viewing.

\_Der Spiegelschrank "Mivedo" ermöglicht dank der drei Spiegeltüren eine dreidimensionale Ansicht.

\_Armoire de toilette "Mivedo" : les trois portes miroir permettent une vue tridimensionnelle.

\_Armario con espejo "Mivedo", gracias a sus tres puertas reflectantes ofrece una visión tridimensional.

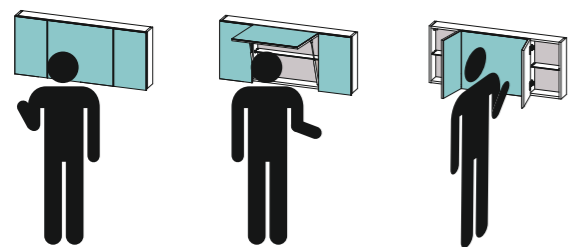



**BASAMENTO  
METALICO  
LACCATO OPACO  
GAMMA BIREX**

- \_Metal base with matt lacquer from the Birex range.
- \_Matt lackiertes Untergestell aus Metall des Produktangebots Birex
- \_Piètement en métal laqué mat gamme Birex
- \_Base metálica lacada mate gama Birex



**CASSETTO INTERNO  
ATTEZZATO**

- \_Accessorised internal drawer
- \_Ausgestattete Innenschublade
- \_Tiroir intérieur aménagé
- \_Cajón interior equipado

# MEMENTO

COMP. 4 L.180 P.50/60 H.190

\_IT Laccato lavanda O153 opaco.

\_EN Matt Lavender O153 lacquer.

\_DE Lavendelblau matt lackiert O153.

\_FR Laqué lavande O153 mat.

\_ES lacado lavanda O153 mate.







**LAVABO  
CONTENITIVO IN  
KORAKRIL™**

- \_ Korakril™ storage washbasin.
- \_ Großes Waschbecken aus Korakril™
- \_ Vasque grande profondeur en Korakril™
- \_ Lavadero en Korakril™



## VERSA

design **IMAGO DESIGN**

**SAGOMATO E COMPONENTIBILE,  
LA SUA LINEA SINUOSA PERMETTE L'INSERIMENTO IN MOLTI  
CONTESTI, AD ANGOLO, VICINO A PORTE/FINESTRE ETC.,  
ABBINABILE AL MODELLO MEMENTO E LOGIKA  
AMPLIA LA GAMMA DI MISURE ED ELEMENTI.**

**\_EN** Shaped and modular, its sinuous line allows it to be inserted in many contexts: in a corner, near doors/windows etc. It can be combined with the Memento and Logika model, extending the range of sizes and elements.

**\_DE** Das sanft gerundete und anbaufähige Modell lässt sich in vielen Raumsituationen einsetzen: in der Ecke, in der Nähe von Türen/Fenstern, etc. In Kombination mit dem Programm Memento und Logika vergrößert sich die Auswahl an Maßen und Elementen.

**\_FR** Modèle galbé et composable. Sa ligne sinueuse permet de l'installer dans de nombreux contextes, en angle, près d'une porte ou d'une fenêtre, etc...S'il est associé au modèle Memento et Logika, il élargit la gamme des dimensions et des éléments à disposition.

**\_ES** Con forma y componible, por su línea sinuosa se puede incorporar a muchos sitios, en esquinas, cerca de puertas/ventanas, etc., y se combina con el modelo Memento y Logika por su extensa gama de medidas y elementos.



# VERSA/BASI LAVABO

COMP. 1 L.120 P.35/52 H.190

\_IT Laccato Bianco 9003 opaco.

\_EN Matt White 9003 lacquer.

\_DE Weiß matt lackiert 9003.

\_FR Laqué blanc 9003 mat.

\_ES Lacado Blanco 9003 mate.

## BASI

Base units  
Unterschranke  
Éléments bas  
Muebles

L. 30/45/60/75/90 cm  
P. 20/35 cm  
H. 48 cm

## BASI LAVABO

Washbasin units  
Waschtisch-Unterschranke  
Éléments sous-vasque  
Muebles lavabo

L. 90/120 cm  
H. 48 cm

## BASI

Base units  
Unterschranke  
Éléments bas  
Muebles

L. 30/45/60/75/90 cm  
P. 20/35 cm  
H. 48 cm

## COLONNE

Tall units  
Hochschranke  
Colonnes  
Columnas

L. 30/45 cm  
P. 35 cm  
H. 120/191 cm

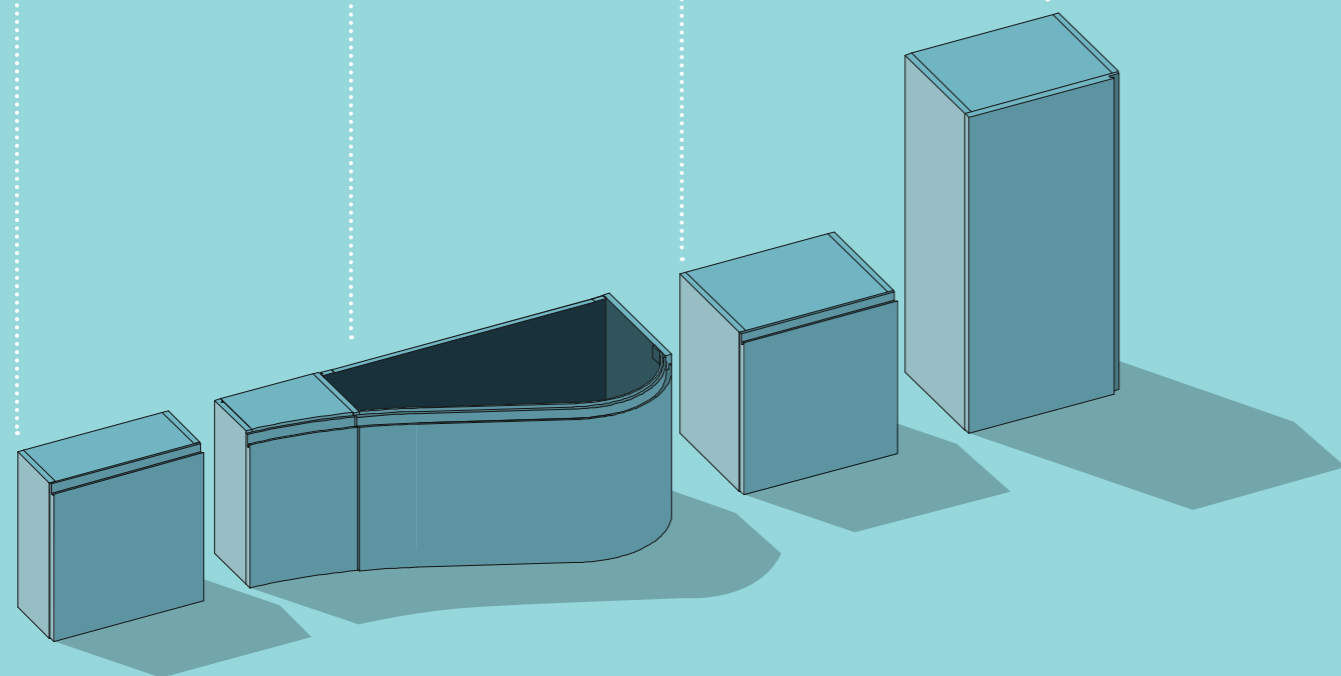





**CASSETTONE  
SAGOMATO  
ATTEZZATO**

- \_ Shaped accessorised deep drawer
- \_ Gerundeter Schubkasten mit Innenausstattung
- \_ Grand tiroir galbé aménagé
- \_ Gaveta con forma equipada

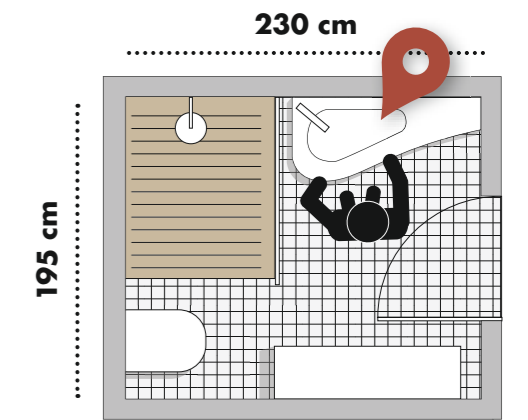



# VERSA

COMP. 2 L.270 P.35/52 H.200

\_IT Laccato Bianco 9003 opaco.

\_EN Matt White 9003 lacquer.

\_DE Weiß matt lackiert 9003.

\_FR Laqué blanc 9003 mat.

\_ES Lacado Blanco 9003 mate.

**DA UN LATO P. 35 CM, DALL'ALTRO P. 20 CM, VERSA È COMPONIBILE NELLE DUE DIVERSE PROFONDITÀ.**

\_With D.35 cm on one side and D. 20 cm on the other, Versa is modular in two different depths.

\_Versa kann in zwei verschiedenen Tiefen zusammengestellt werden: auf einer Seite T. 35 cm, auf der anderen Seite T. 20 cm

\_D'un côté prof. 35 cm et de l'autre prof. 20 cm. Versa peut se composer avec les deux différentes profondeurs.

\_Por un lado P. 35 cm, por el otro P. 20 cm, versa es componible en sus dos distintas medidas de fondo.









**LA SCARPIERA  
IN BAGNO**

- \_A shoe rack in the bathroom
- \_Der Schuhrack im Badezimmer
- \_Le range-chaussures dans la salle de bains
- \_El zapatero en el baño



## VERSA/COMPOSIZIONE AD ANGOLO

\_Corner composition  
\_Eck-Zusammenstellung  
\_Composition d'angle  
\_Composició de esquina

**COMP. 3 L.180 P.20/52 H.200**

\_IT Laccato O69 grigio  
polvere opaco.

\_EN Matt Dusty Grey O69  
lacquer.

\_DE Pulvergrau matt lackiert  
O69.

\_FR Laqué gris poudre O69  
mat.

\_ES lacado O69 gris polvo  
mate.



## SPECCHIO "JAZZ" CON LUCE LED PERIMETRALE

\_ "Jazz" mirror with  
perimeter LED light  
\_ Spiegel "Jazz" mit  
umlaufender LED-  
Beleuchtung  
\_ Miroir "Jazz" avec  
éclairage à leds  
périphérique  
\_ Espejo "Jazz" con luz  
de leds perimétrica



## PIANO INTEGRATO IN VETRO, LACCATO GAMMA BIREX

\_ Built-in glass top, in any lacquer  
from the Birex range  
\_ Waschtischplatte aus Glas mit  
integriertem Becken, lackiert  
nach Farbpalette Birex  
\_ Plan-vasque en verre laqué  
gamme Birex  
\_ Encimera integrada de cristal,  
lacada gama birex



## VERSA/VANI A GIORNO

- \_Open units
- \_Offene Fächer
- \_Éléments ouverts
- \_Compartimentos abiertos

### PENSILI

Wall units  
Wandschränke  
Éléments à suspendre  
Armarios

L. **30/45/60/75/90** cm  
P. **20** cm  
H. **24** cm

### PENSILI

Wall units  
Wandschränke  
Éléments à suspendre  
Armarios

L. **30/45** cm  
P. **20** cm  
H. **36/48/60** cm

### BASI

Base units  
Unterschränke  
Éléments bas  
Muebles

L. **30/45** cm  
P. **35/50** cm  
H. **24/36/48/60** cm

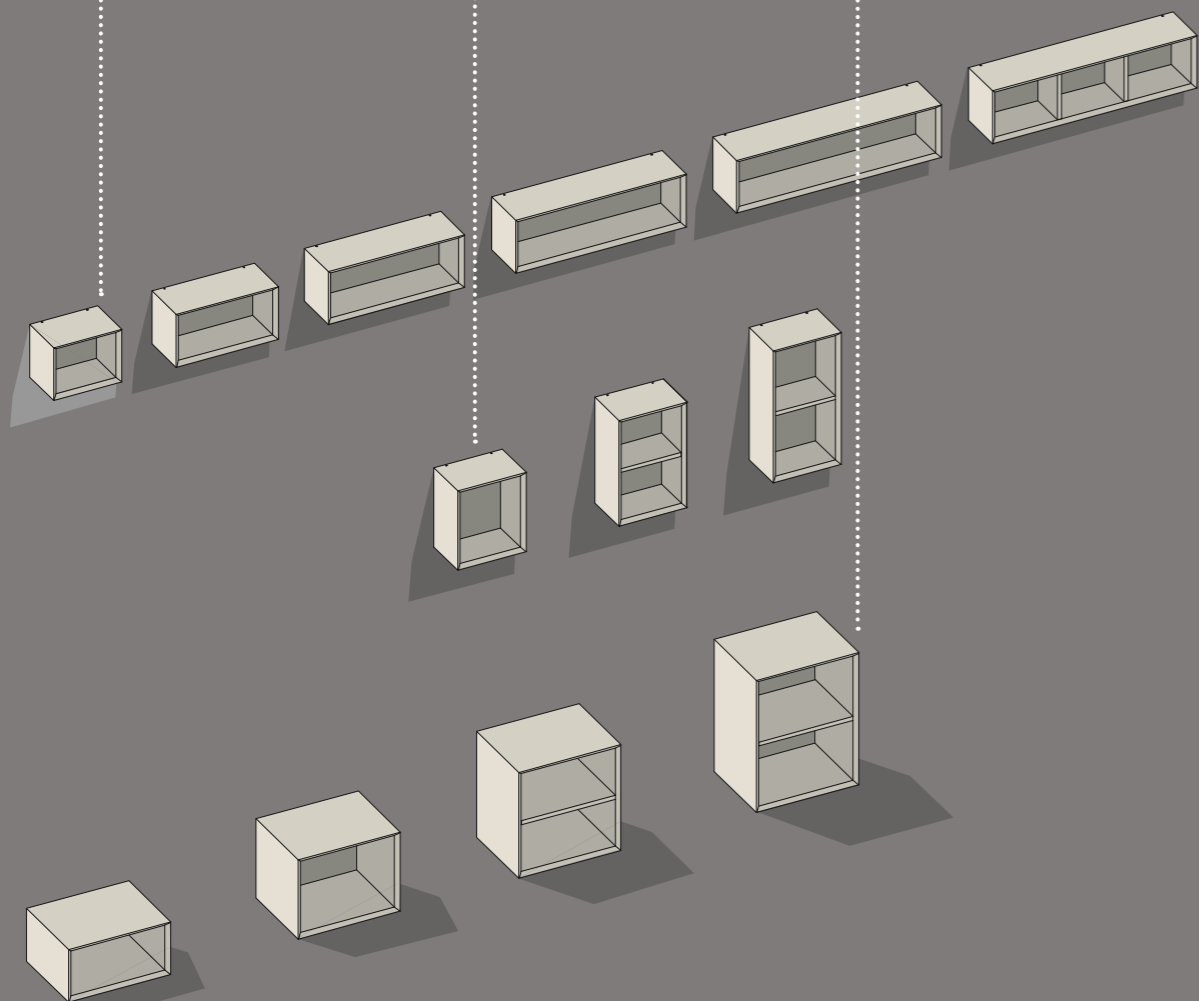

## VANO A GIORNO CON TAGLIO 45°

- \_Open unit with 45° edges
- \_Offenes Fach mit 45°-Zuschnitt
- \_Élément ouvert avec coupe à 45°
- \_Compartimento abierto con corte de 45°





## CAMPUS

design **IMAGO DESIGN**

**È UN BAGNO MINIMAL DALLE FORME MORBIDE, ISPIRATO ALL'ARMONIA DI UNA GOCCIA D'ACQUA. GLI ARREDI NE ACCOMPAGNANO LE LINEE ARROTONDATE, GLI ANGOLI SI INGENTILISCONO, I LAVABI DA APPOGGIO SEMBRANO SCAVATI DA QUELLE STESSO GOCCE, CHE PAIONO AVER PLASMATO ANCHE I LAVABI INTEGRATI, INVECE TERMOFORMATI CON TECNICHE MODERNE.**

**\_EN** A minimalist bathroom with soft shapes, inspired by the harmony of water drops. The furniture has rounded shapes and softened corners. Surface-mounted washbasins appear to be sculpted by water drops, which seem to have moulded even the built-in washbasins which are instead thermoformed using modern technologies.

**\_DE** Ein minimalistisches Bad mit weichen Formen, das sich von der Harmonie eines Wassertropfens inspirieren lässt. Die Möbelemente folgen den gerundeten Linien, die Kanten sind sanft geformt, die Aufsatzbecken scheinen aus den gleichen Tropfen herausgearbeitet zu sein, die auch den integrierten, mit modernen Techniken wärmegeformten Becken ihre Gestalt geben.

**\_FR** Il s'agit d'une salle de bains minimaliste aux formes douces s'inspirant de l'harmonie d'une goutte d'eau. Les divers compléments en accompagnent les lignes arrondies, les angles s'adoucissent, les vasques à poser semblent creusées par ces gouttes d'eau qui semblent avoir également façonné les vasques intégrées, thermoformées en revanche par des techniques modernes.

**\_ES** Es un baño minimal con formas suaves, que se inspira en la armonía de una gota de agua. El mobiliario acompaña sus líneas redondeadas, las esquinas se suavizan, los lavabos de sobremueble parecen cavados por esas mismas gotas, que también han modelado los lavabos integrados, en realidad termoformados con las técnicas más modernas.



# CAMPUS/BASI LAVABO SFUMATE

COMP. 1 L.83 P.52 H.200

**\_IT** Laccato sfumato Lavanda / giallo zinco O135 opaco.

**\_EN** Shaded Lavender / matt Zinc Yellow O135 lacquer.

**\_DE** Lackierung mit Farbverlauf Lavendelblau / Zinkgelb matt O135.

**\_FR** Laqué nuancé lavande / jaune zinc O135 mat.

**\_ES** Lacado degradado Lavanda / amarillo cinc O135 mate.

**1**  
lavanda O253  
giallo zinco O135

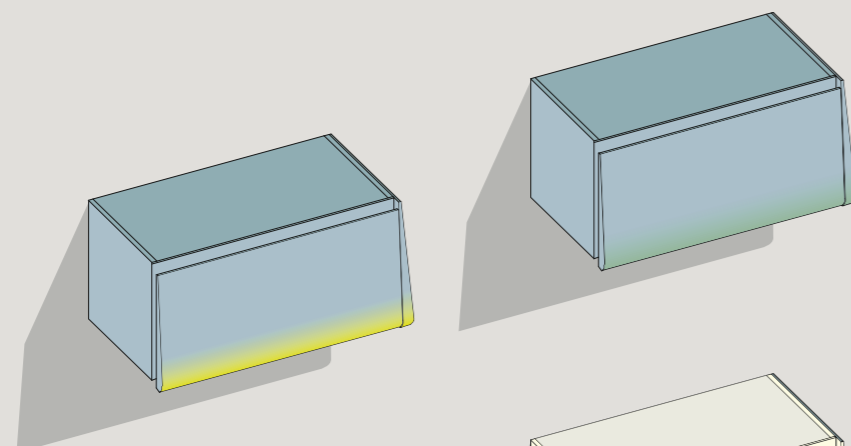

**2**  
panna O9010  
giallo zinco O135

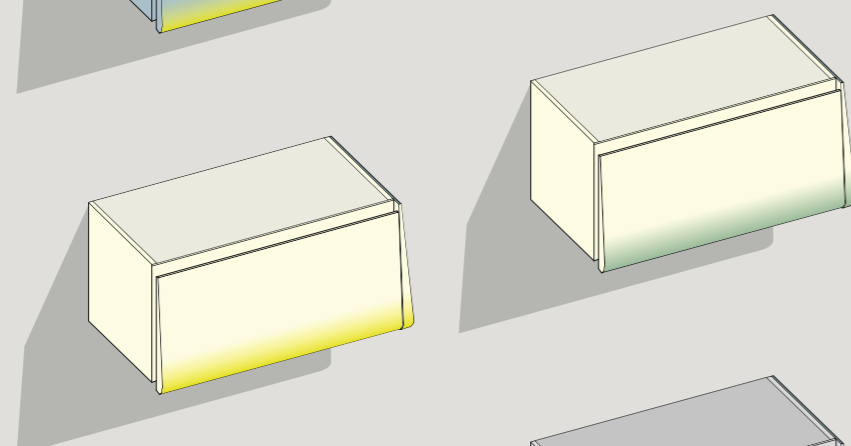

**3**  
grigio chiaro O7035  
lavanda O253

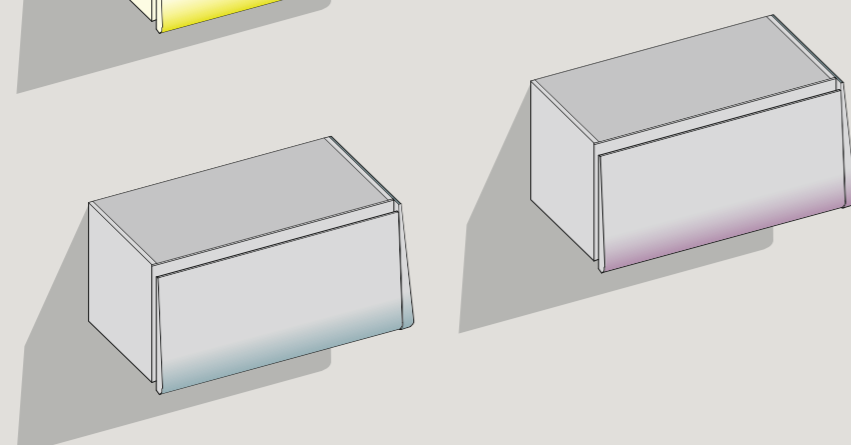

**4**  
lavanda O253  
verde pompelmo O65

**5**  
panna O9010  
verde pallido O190

**6**  
grigio chiaro O7035  
lilla O67







**PIANO IN VETRO  
LACCATO IN TINTA  
CON LA SCOCCA**

- \_Lacquered glass top in the same colour as the structure
- \_Waschtischplatte aus Glas, in Korpusfarbe lackiert
- \_Plan en verre laqué assorti à la finition du caisson
- \_Encimera de cristal lacada a tono con la estructura







### SPECCHI TONDI

Round mirrors  
Runde Spiegel  
Miroirs ronds  
Espejos redondos

Ø 25/40/70/90 cm

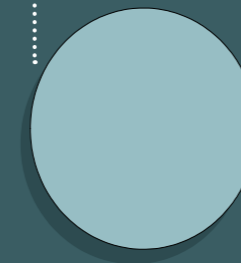

### LAMPADA SLIM A MURO

Slim wall-mounted light.  
Wandleuchte Slim  
Spot mural Slim  
luz slim de pared

Ø 10

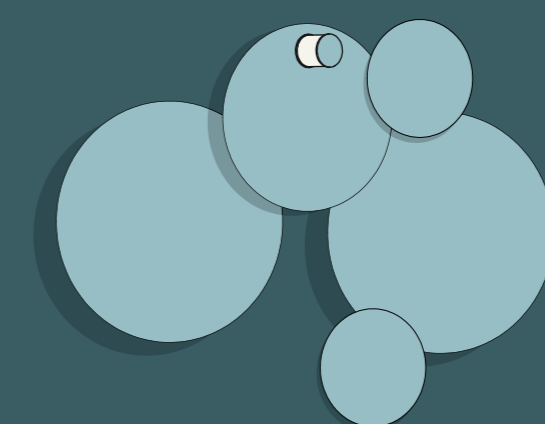

### SPECCHI SOVRAPPONIBILI CON DIVERSE PROFONDITÀ

\_overlapping mirrors in  
different depths  
\_Die Spiegel können mit  
verschiedenen Tiefen  
übereinandermontiert werden  
\_Miroirs superposables avec  
différentes profondeurs  
\_Espejos sobreponibles de  
distinta profundidad



# CAMPUS

COMP. 2 L.120+45 P.52 H.190

\_IT Laccato Bianco 9003 opaco.

\_EN Matt White 9003 lacquer.

\_DE Weiß matt lackiert 9003.

\_FR Laqué blanc 9003 mat.

\_ES lacado 9003 blanco mate.





## CAMPUS/COLONNE

\_Vertical pillar units  
\_Hochschränke  
\_Colonnes  
\_Columnas

### COLONNE

Vertical pillar units  
Hochschränke  
Colonnes  
Columnas

L. 30/45 cm  
P. 35 cm  
H. 120/192 cm

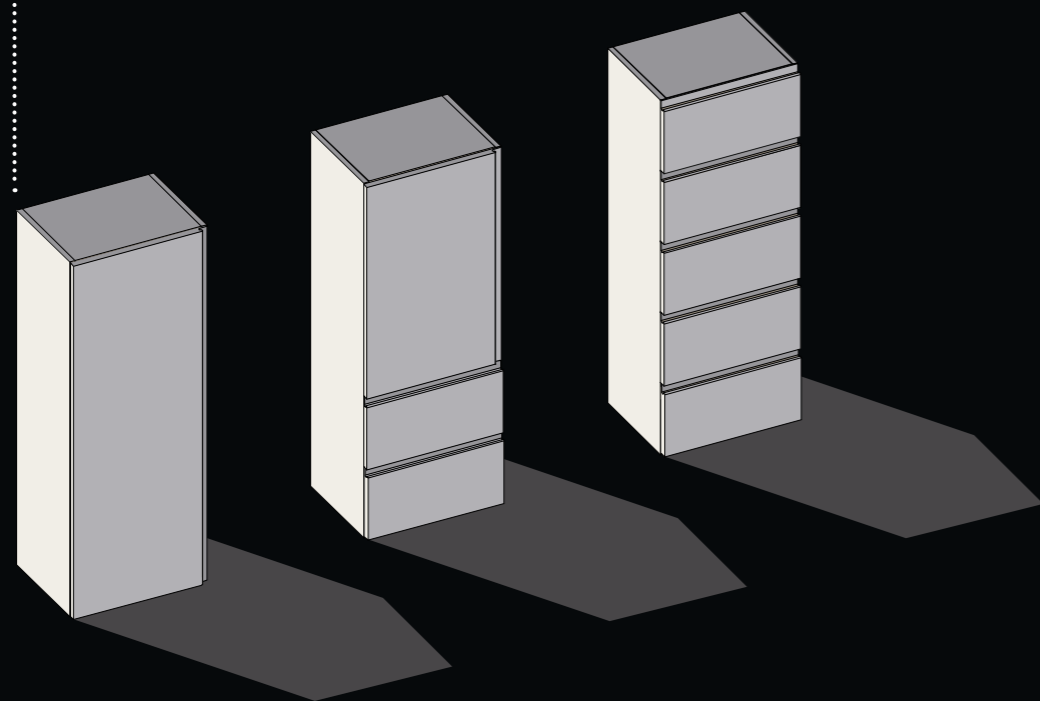

### COLONNA ATTREZZATA PER IL TRUCCO

\_Accessorised vertical unit  
for makeup.  
\_Hochschrank mit  
Innenausstattung für  
Schminkutensilien.  
\_Colonne aménagée pour  
le maquillage.  
\_Columna equipada para  
el maquillaje.



## CAMPUS

COMP. 3 L.158 P.52 H.200

\_IT Laccato O61 corda opaco.

\_EN matt cord O61 lacquer.

\_DE Kordel matt lackiert O61.

\_FR Laqué corde O61 mat.

\_ES Lacado O61 cuerda mate.

### PIANO IN VETRO LACCATO IN TINTA CON LA SCOCCA

\_Lacquered glass top in the same colour as the structure  
\_Waschtischplatte aus Glas, in Korpusfarbe lackiert  
\_Plan en verre laqué assorti à la finition du caisson  
\_Encimera de cristal lacada a tono con la estructura





## CAMPUS/BASI COMPONIBILI

- \_Modular base units
- \_Anbaufähige Unterschränke
- \_Éléments bas composables
- \_Muebles componibles

### BASI LAVABO

Washbasin units  
Waschtisch-Unterschränke  
Éléments sous-vasque  
Muebles lavabo

L. 75/90/120 cm  
P. 37/52 cm  
H. 48 cm

### BASI

Base units  
Unterschränke  
Éléments bas  
Muebles

L. 45 cm    L. 75 cm    L. 90 cm

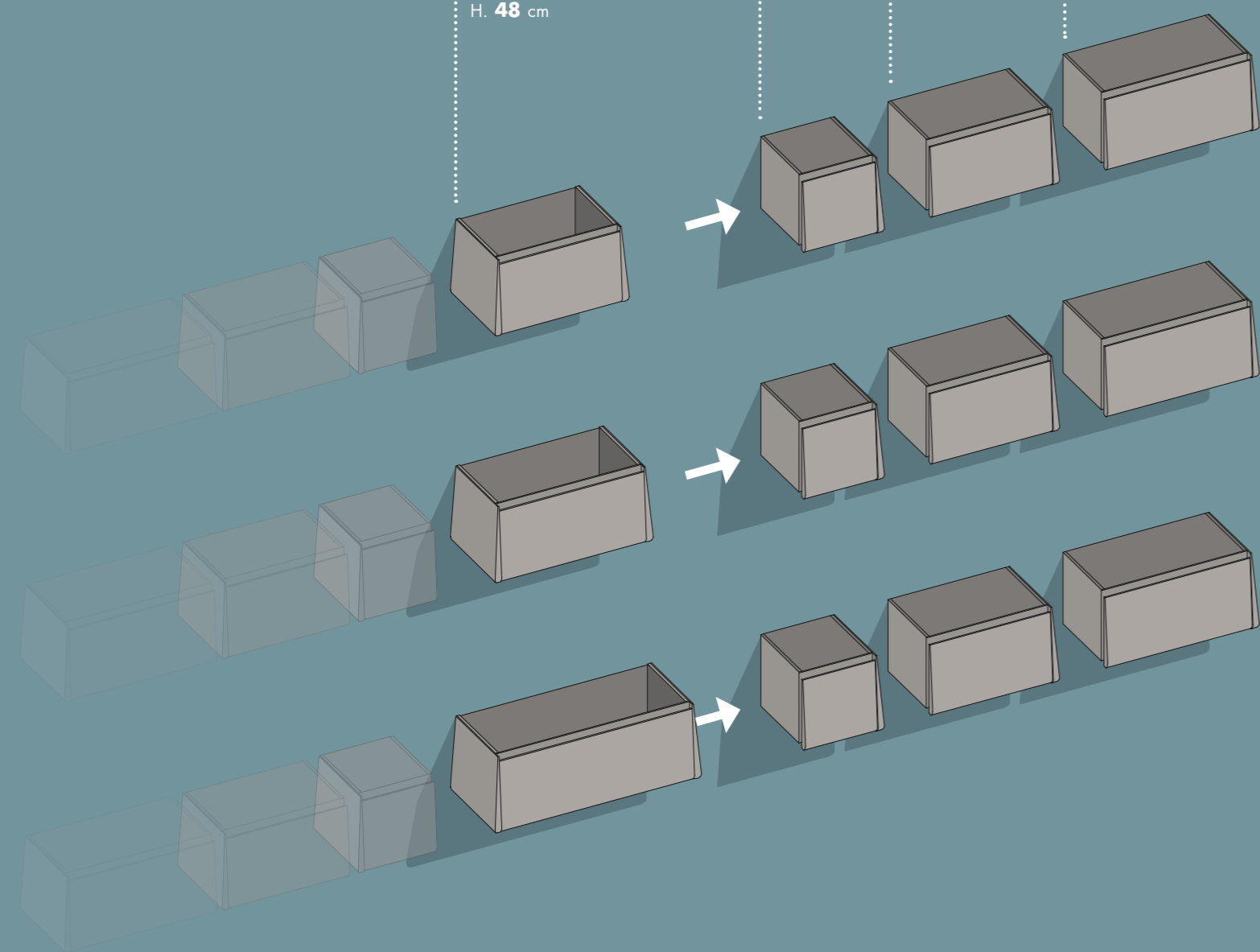



**abaco**  
**prodotti/**  
**caratteristiche**  
**tecniche**

**\_EN** Abaco products / technical features

**\_DE** Produkteverzeichnis / Technische Eigenschaften

**\_FR** abaque des produits / caractéristiques techniques

**\_ES** ábaco productos / características técnicas



# LAVABO CERAMICA/MINERALMARMO

\_Ceramic/mineralmarmo washbasin  
\_Waschtisch aus Keramik/Mineralmarmor  
\_Vasques à poser en céramique/Mineralmarmo  
\_Lavabo de cerámica/mármol sintético

**SEED**  
Ø 40 H.18



**SEED**  
L.40 P.45 H.15



**CIOTOLA**  
Ø 46 H.20



**TRACE**  
Ø 40 H.18



**POLIS**  
Ø 43 H.13



**SKIN** (mineralmarmo)  
L.38 P.38 H.14



**SKIN** (mineralmarmo)  
Ø 38 H.14



**TEOREMA**  
L.46 P.46 H.14



**SEED**  
L.55 P.40 H.24



**SEED**  
L.55 P.30 H.18



**CIOTOLA**  
L.59 P.42 H.17



**TRACE**  
L.38 P.38 H.15



**OVO**  
L.42 P.33 H.14



**SKIN** (mineralmarmo)  
L.58 P.38 H.14



**SKIN** (mineralmarmo)  
L.58 P.38 H.14



**TEOREMA R**  
L.46 P.46 H.14



**SEED**  
L.70 P.40 H.13



**CIOTOLA**  
L.70 P.44 H.20



**TRACE**  
L.65 P.38 H.12



**PLETTO**  
L.60 P.44 H.15



**NINIVE**  
L.90 P.45 H.20



## LAVABO AD INCASSO

\_Built-in washbasin  
\_Einbauwaschtisch  
\_Vasques à encastrer  
\_Lavabo de encastre

**GAIA**  
L.56 P.39,5 H.2



**SKIN** (mineralmarmo)  
Ø 38 H. 4,5



**SKIN** (mineralmarmo)  
L.38 P.38 H.4,5



**PLANO** (mineralmarmo)  
L.54.5 P.37 H.1,5



**SFERA**  
Ø 40 H.2



**SKIN**  
L.58 P.38 H.4,5



**SKIN** (mineralmarmo)  
L.58 P.38 H.4,5



## ACCESSORI/BIANCHI E CROMO

\_Accessories/White lacquer and steel  
\_Zubehörteile/Weiß lackiert und Stahl  
\_Accessoires/laqués blancs et chromés  
\_Barnizados en blanco y acero



\_Finitura bianco  
\_White finish  
\_Ausführung Weiß  
\_Finition blanche  
\_Acabado blanco



\_Finitura cromo  
\_Chrome finish  
\_Ausführung Chrom  
\_Finition chromée  
\_Acabado cromo



## SPECCHI CONTENITORI E FUNZIONALI

\_Functional and storage mirrors \_Spiegelschränke und Funktionsspiegel  
\_Miroirs \_Armarios con espejo y funcionales

**PENSILE SPECCHIO  
STENDINO**  
L.90 P.10 H.45



**ACQUA E SAPONE**  
L.50 P.19 H.50



**SPECCHIO RANDOM**  
TIPO A \_ L.87 P.2.5 H.89



TIPO B \_ L.102 P.2,5 H.99



TIPO C \_ L.116 H.2.5 P. 93



**SPECCHIO 45°**  
L.45/60/75/90/105/120  
P.20 H. 36/48/60



**SIDE**  
L.52 P.27 H. 96/120



TIPO D \_ L.120 P.2.5 H. 100



TIPO E \_ L.144 P. 2.5 H.100



TIPO F \_ L.165 P.2.5 H.90



**MIVEDO**  
L.120 P. 15 H. 51



## SPECCHI SAGOMATI

\_Shaped mirrors \_Rechteckige Spiegel Geformte Spiegel  
\_Miroirs galbés \_ espejos con forma

**JAZZ**  
L.160 P.2.5 H.95



**ROTONDO CON  
LAMPADA**  
Ø 70 P. 2.5



**SAGOMATA**  
L.48/120 P.2.5 H.48/96/120



**FILO LUCIDO**  
L.60/75/90/105/120/135/1  
50/165/180 P.2.5  
H. 48/60/72/96/192



**QUADRA**  
L.90 P.2,5 H.60



**JAZZ**  
L.80 P.2,5 H.115



**ROTONDO**  
Ø 90/70/40/25  
P. 1.5/2/2.5/3



**FRAME**  
L. 60/75/90/120 P. 2.5  
H. 60/72/90



**RADIUS**  
L.75 H.75



**DROP**  
L.51 P.2.5 H.69  
L.39 P.2.5 H. 39  
L.30 P.2.5 H.30



**RIGA**  
L.90/105/120 P.2.5 H. 72



## CARATTERISTICHE TECNICHE

\_Technical features  
 \_Technische Merkmale  
 \_Caractéristiques techniques  
 \_Especificaciones técnicas

\_Barra di rinforzo in alluminio.  
 \_Reinforced bar in aluminum.  
 \_Griffprofil aus Aluminium, in gleicher Farbe lackiert.  
 \_Barre de renfort en aluminium.  
 \_Barra de refuerzo de aluminio.



\_Attaccaglia alta portata con tripla regolazione e sistema antisgancio.  
 \_High-capacity fixing, 3-way adjustment and anti-release system.  
 \_Suspension charge lourde avec triple réglage et système anti-décrochage.  
 \_Herraje de gran capacidad con tres regulaciones y sistema anticaída.



\_Profilo gola in alluminio laccato in tinta.  
 \_Grip-recess profile in aluminium lacquered in the same colour.  
 \_Verstärkungsstange aus Aluminium  
 \_Profil gorge en aluminium laqué et assorti au caisson.  
 \_Perfil ranura de aluminio lacado a tono.



\_Pannello ecologico, certificato classe E1, idrofugo.  
 \_Water-resistant, Class E1 eco-panel.  
 \_Ökologisch nachhaltige Platte, Zertifikat E1, wasserabweisend.  
 \_Panneau écologique certifié E1, hydrofuge.  
 \_Panel ecológico, certificado E1, hidrófugo.

\_Cassettoni metallici ad estrazione totale con chiusura rallentata Blumotion.  
 \_Full-extraction metal deep drawer with Blumotion soft closing system.  
 \_Schubkasten aus Metall mit Vollauszug und gebremstem Schließmechanismus Blumotion.  
 \_Gaveta metálica de extracción total con cierre amortiguado Blumotion.



\_Cerniera con chiusura ammortizzata integrata a scomparsa Salice.  
 \_Hinge Salice with integrated retractable soft closing.  
 \_Einziehbarer Scharnier Salice mit gedämpfter Schliessung.  
 \_Charnière Salice avec fermeture ralentie intégrée.  
 \_Bisagra con cierre amortizado mod. Salice.



\_Ripiano vetro rinforzato sp. 6 mm.  
 \_Reinforced glass shelf Th. 6 mm.  
 \_Einlegeboden aus verstärktem Glas St. 6 mm.  
 \_Tablette en verre renforcé ép. 6 mm.  
 \_Balda de cristal reforzada esp. 6 mm.



\_Frontale in MDF leggero trattato poliesteri.  
 \_Polyester-coated light MDF front.  
 \_Front aus leichtem MDF mit Polyesterbehandlung  
 \_Façade en MDF léger traité polyester  
 \_Frente de MDF liviano tratado con poliéster



**art direction**

Genny Canton Studio

**graphics and layout**

Genny Canton Studio

**photography**

Beppe Brancato

**styling**

Martina Sanzarelo

**print**

Grafiche Antiga

**thanks to**

Acca Kappa  
Ceratina 1919  
Essential  
Gabel  
Incipit Lab

**BIREX**

Via Mazzini, 3  
33070 Maron di Brugnera (PN) Italy  
Tel. +39 0434 565751 r.a.  
Fax +39 0434 99151  
birex@birex.it  
www.birex.it